

VHF FM TRANSCEIVER

IC-H16

SERVICE MANUAL



ICOM INCORPORATED

1-6-19, Kamikuratsukuri, Hirano-ku, Osaka 547, Japan
Phone: (06) 793-5301
Telex: ICOM TR J63649

ICOM AMERICA, INC.

2380 116th Avenue N.E.
Bellevue, Washington 98004
Phone: (206) 454-8155
Telex: 230-152210 ICOM AMER BVUE
Fax: (206) 454-1509

3331 Towerwood Drive
Suite 307
Dallas, Texas 75234
Phone: (214) 620-2781
Telex: 230-730901 ICOM AMER DAL

1777 Phoenix Parkway
Suite 201
Atlanta, Georgia 30349
Phone: (404) 991-6166

ICOM (EUROPE) GmbH

Himmelgeister strasse 100
4000 Düsseldorf 1
West Germany
Phone: 0211-346047
Telex: 41-8588082 ICOM D
Fax: 211-333639

ICOM CANADA LTD.

3071-#5 Road, Unit 9
Richmond, B.C.
V6X 2T4 Canada
Phone: (604) 273-7400
Fax: (604) 273-1900

ICOM AUSTRALIA, PTY., LTD.

7 Duke street, Windsor 3181
Victoria, Australia
Phone: (03) 529-7582
Telex: 71-35521 ICOMAS

FOREWORD

Thank you for choosing the ICOM **IC-H16**, one of the most advanced VHF portables on the Land Mobile market today.

Utilizing sophisticated computer based technology and ICOM's precision VHF engineering, the **IC-H16** incorporates state-of-the-art design concepts to meet the demanding needs and requirements of the Land Mobile user.

ASSISTANCE

There are three different versions of the **IC-H16**. This service manual is designed to cover every version. Each model is assigned a particular number as follows.

Version No.	Version	Frequency range	Channel spacing
#01	U.S.A.	148.00 ~ 174.00MHz	25kHz
#02	U.S.A.	136.00 ~ 144.00MHz	25kHz
#03	U.K.	148.00 ~ 174.00MHz	12.5kHz

Please contact your nearest ICOM Service center if you require assistance or information regarding the operation and capabilities of the **IC-H16**. Addresses are provided on the title page of this manual.

TABLE OF CONTENTS

SECTION 1 SPECIFICATIONS	1 – 1
SECTION 2 OPERATING CONTROLS	2 – 1
SECTION 3 INSIDE VIEWS	3 – 1
SECTION 4 BLOCK DIAGRAM	4 – 1
SECTION 5 CIRCUIT DESCRIPTION	5 – 1 ~ 7
5 - 1 RECEIVER CIRCUITS	5 – 1
5 - 2 TRANSMITTER CIRCUITS	5 – 1
5 - 3 PLL CIRCUITS	5 – 2
5 - 4 POWER SUPPLY CIRCUITS	5 – 3
5 - 5 LOGIC CIRCUITS	5 – 3
SECTION 6 MECHANICAL PARTS AND DISASSEMBLY	6 – 1 ~ 5
6 - 1 DISASSEMBLY OF THE CASE	6 – 1
6 - 2 DISASSEMBLY OF THE TOP PANEL	6 – 3
6 - 3 PA AND EXTERNAL JACK ASSEMBLY	6 – 3
6 - 4 SPEAKER AND MICROPHONE ASSEMBLY	6 – 4
6 - 5 DISPLAY UNIT AND LCD ASSEMBLY	6 – 4
6 - 6 PTT SPRING ASSEMBLY	6 – 5
6 - 7 UNIT BOTTOM ASSEMBLY	6 – 5
SECTION 7 MAINTENANCE AND ADJUSTMENT	7 – 1 ~ 5
7 - 1 PREPARATION BEFORE SERVICING	7 – 1
7 - 2 POWER SUPPLY CHECKS	7 – 2
7 - 3 PLL ADJUSTMENT	7 – 3
7 - 4 TRANSMITTER ADJUSTMENT	7 – 4
7 - 5 RECEIVER ADJUSTMENT	7 – 5
SECTION 8 VOLTAGE DIAGRAMS	8 – 1 ~ 4
8 - 1 MAIN UNIT	8 – 1
8 - 2 PLL UNIT	8 – 2
8 - 3 LOGIC UNIT	8 – 3
8 - 4 DISPLAY UNIT	8 – 4
SECTION 9 BOARD LAYOUTS	9 – 1 ~ 4
9 - 1 MAIN UNIT	9 – 1
9 - 2 PLL UNIT	9 – 2
9 - 3 LOGIC UNIT	9 – 3
9 - 4 DISPLAY UNIT	9 – 4
SECTION 10 PARTS LIST	10 – 1 ~ 6
SECTION 11 IC SPECIFICATIONS	11 – 1 ~ 9
SECTION 12 BATTERY PACK SCHEMATIC DIAGRAMS	12 – 1 ~ 2
12 - 1 IC-CM7	12 – 1
12 - 2 IC-CM8	12 – 2
SECTION 13 SCHEMATIC DIAGRAM	SEPARATE
SECTION 14 PROGRAMING MANUAL	SEPARATE

SECTION 1 SPECIFICATIONS

GENERAL

Frequency range	: 148.00MHz~174.00MHz (#01, #03) 136.00MHz~144.00MHz (#02)
Number of channels	: 16 channels (keyboard programmable) Simplex, semi-duplex operation
Usable temperature	: -30°C~+60°C (-22°F~+140°F)
Channel spacing	: 25kHz (#01, #02) 12.5kHz (#03)
Frequency stability	: ±0.0005%
Antenna impedance	: 50 ohms unbalanced
Power supply requirement	: 8.4V DC with IC-CM8 attendant battery pack (negative ground)
Current drain	: Transmit : 1150mA approx. Receive : 200mA approx. Standby : 65mA approx. (35mA with power saver)
Dimensions	: 65(74)mm(W) × 196(207)mm(H) × 38(41)mm(D) Bracketed values include projections.
Weight	: 595g including IC-CM8 battery pack.

RECEIVER

Receiving system	: Double-conversion superheterodyne
Modulation acceptance	: 16K0F3E
Intermediate frequency	: 1st: 21.8MHz 2nd: 455kHz
Sensitivity	: Less than 0.4μV for 12dB SINAD
Audio output power	: 500mW minimum at 10% distortion with 8 ohms load.
Audio output impedance	: 8 ohms

TRANSMITTER

Output power	: HIGH 2.5W LOW 0.5W (with IC-CM8) HIGH 5.0W LOW 0.5W (with IC-CM7)
Emission mode	: 16K0F3E
Modulation system	: Variable reactance frequency modulation
Microphone	: Built-in electret condenser microphone

SECTION 2 OPERATING CONTROLS

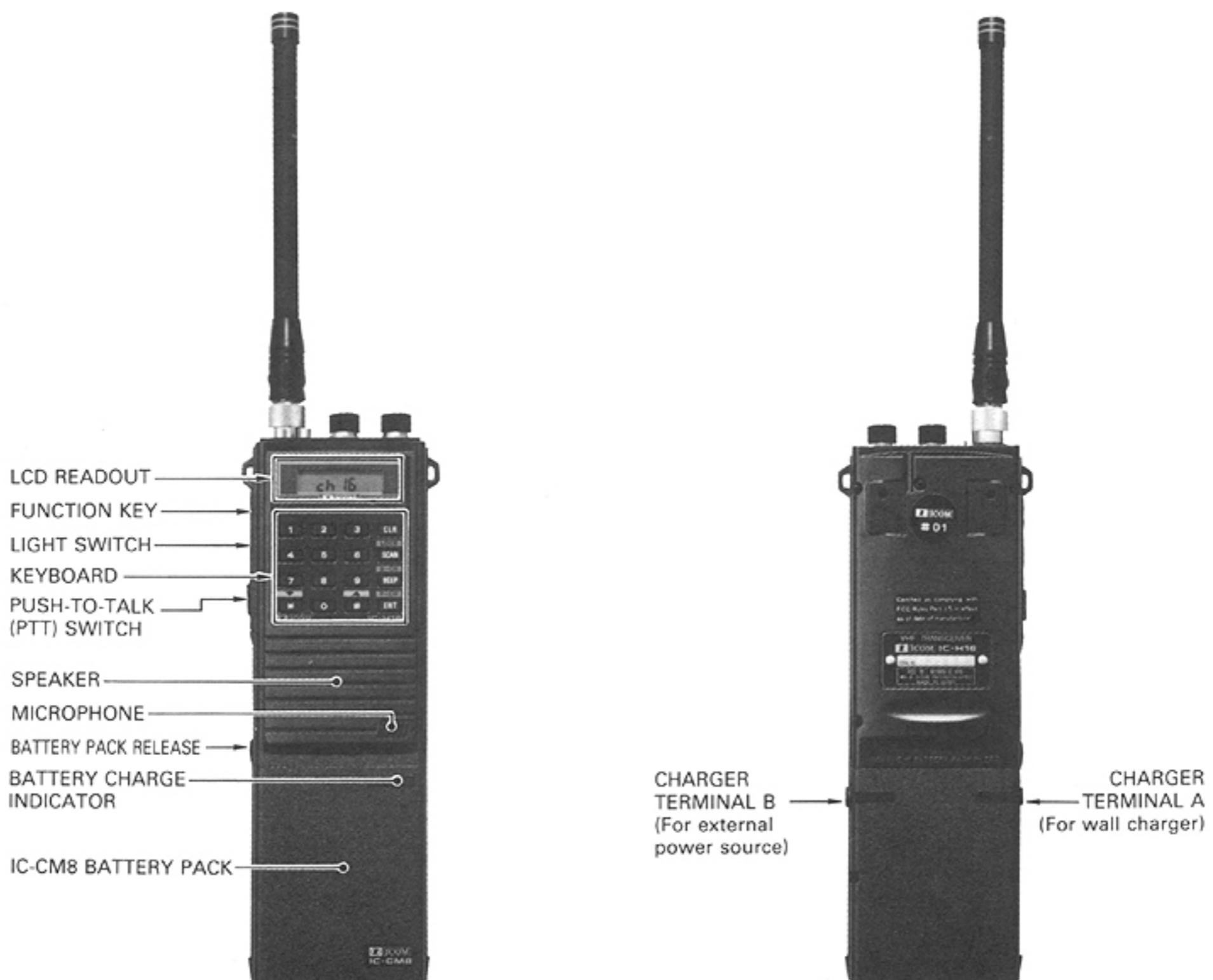
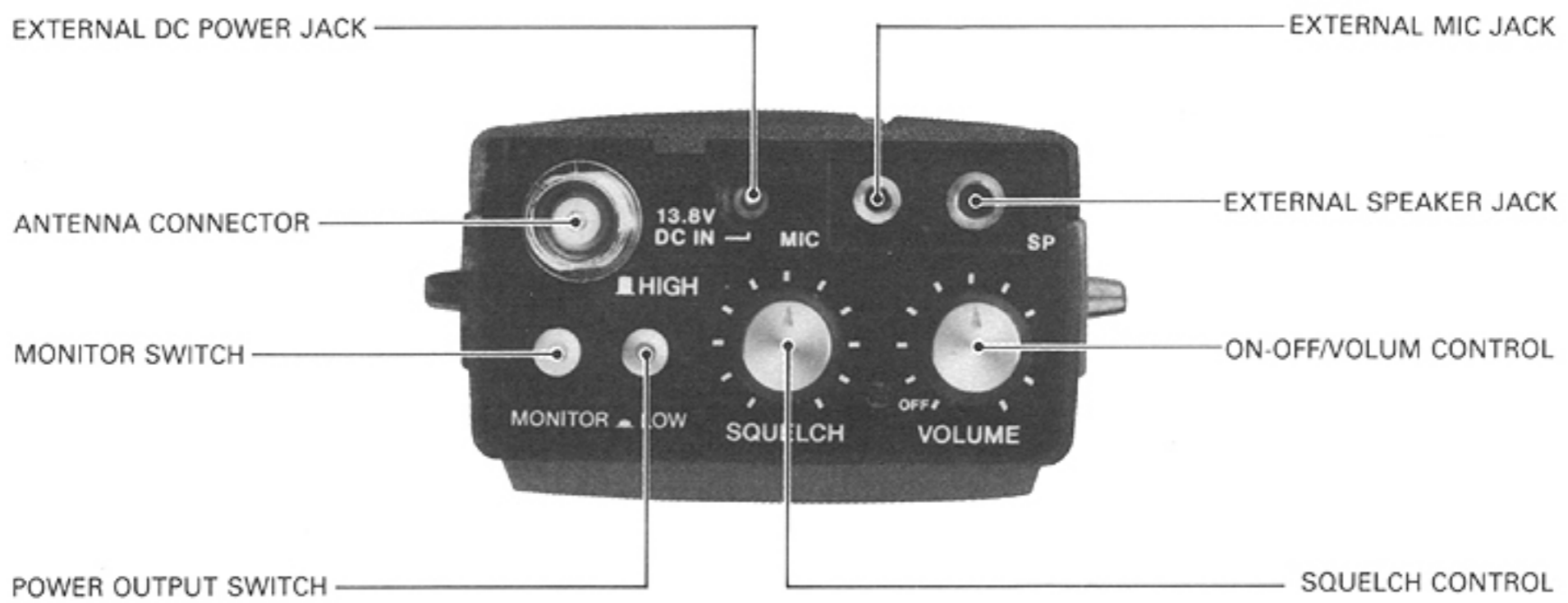

SECTION 3 INSIDE VIEWS

MAIN/PLL UNIT

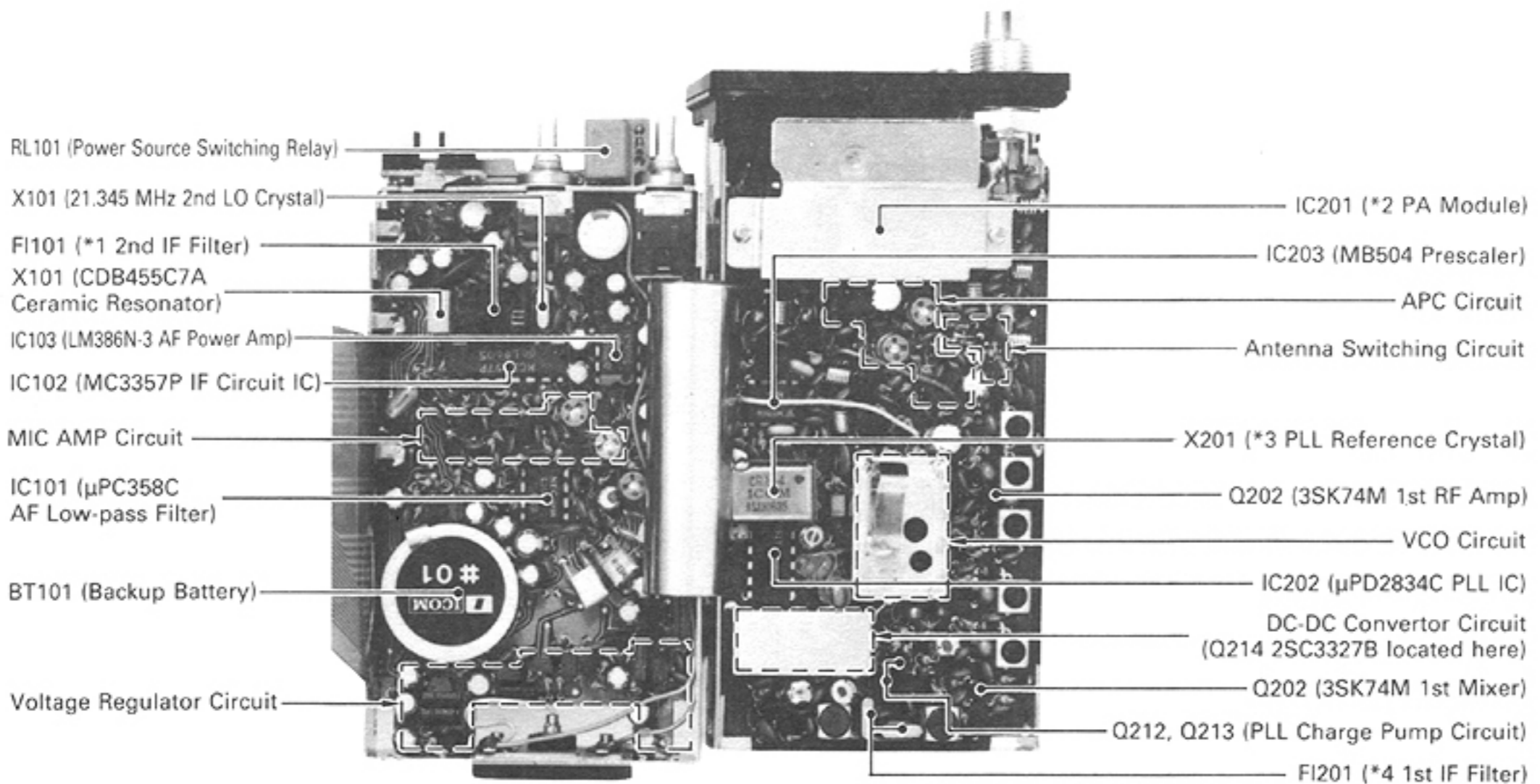

MAIN UNIT

PLL UNIT

- *1 FI101 CFW455E (#01, #02) CFW455HT (#03)
- *2 IC201 SC-1046 (#01, #03) SC-1050 (#02)
- *3 X201 5.12 MHz (#01, #02) 6.4 MHz (#03)
- *4 FI201 21M15B3 (#01, #02) 21M7B2 (#03)

LOGIC/DISPLAY UNIT

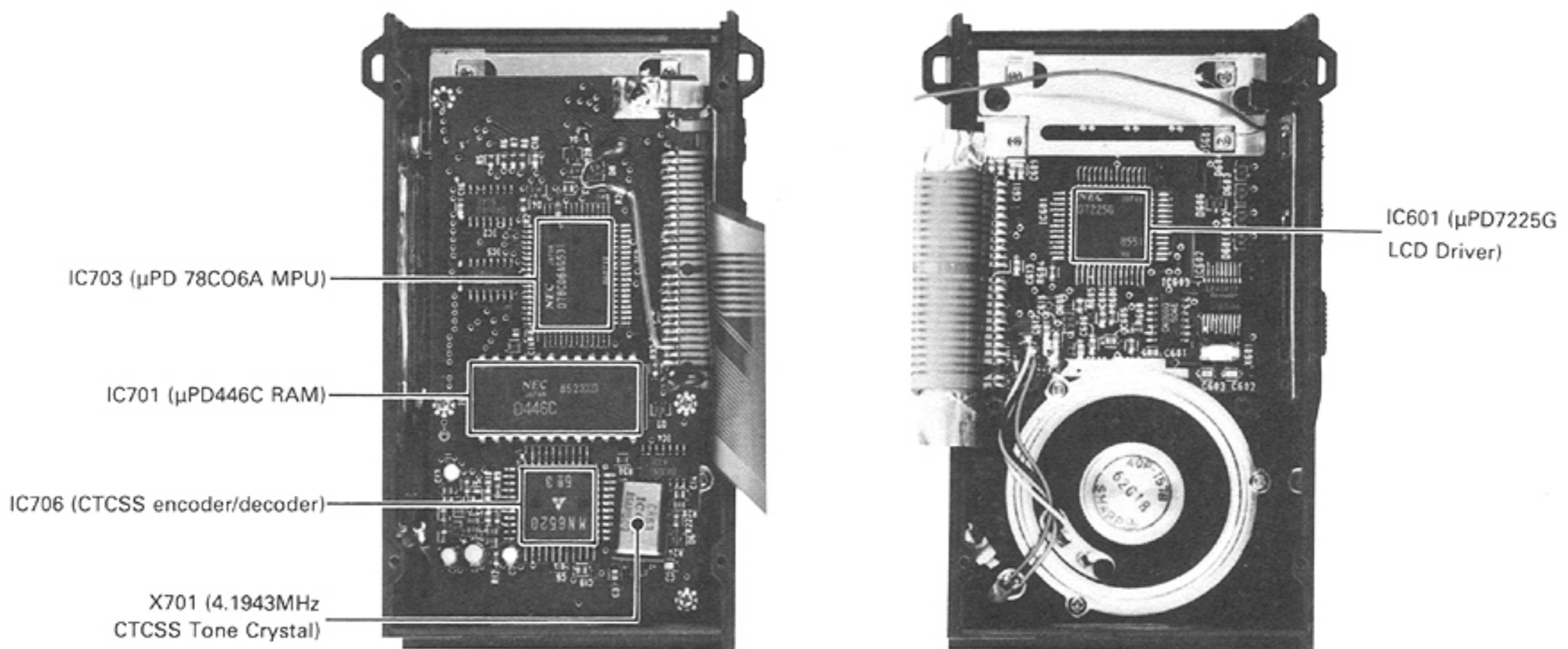

LOGIC UNIT

DISPLAY UNIT

SECTION 4 BLOCK DIAGRAM

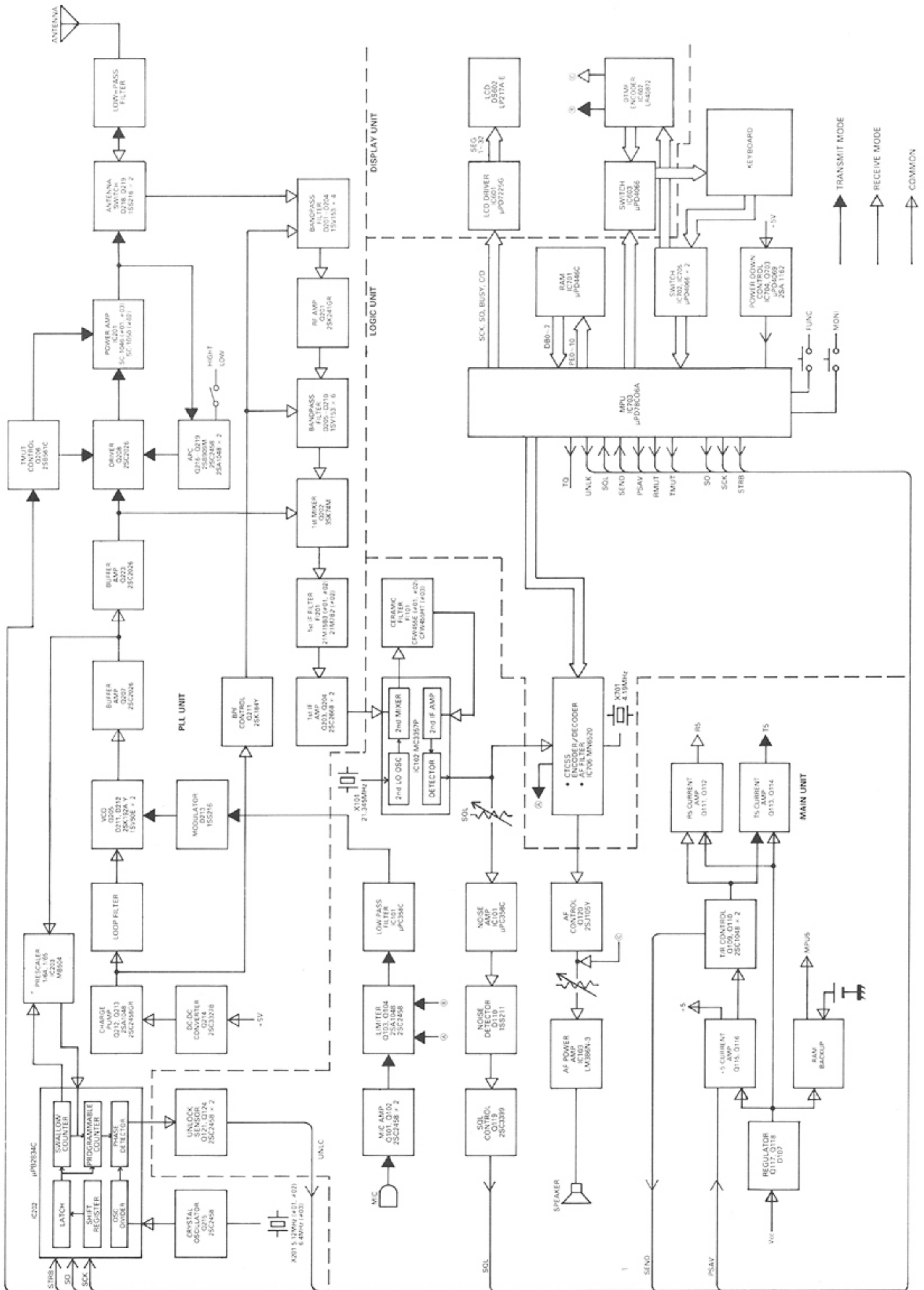

SECTION 5 CIRCUIT DESCRIPTION

5 - 1 RECEIVER CIRCUITS

5 - 1 - 1 ANTENNA SWITCHING CIRCUIT

Input signals from the antenna connector are fed into the antenna switching circuit through low-pass filter consisting of C270, L219, C269, L218, C268, C267 and C266 on the PLL unit. The antenna switching circuit employs a quarter wave circuit consisting of D218, D219, C264, C265 and L217.

5 - 1 - 2 RF AMPLIFIER CIRCUIT

Signals from the switching circuit pass through bandpass filters consisting of L201, C202, D201, D202, D203, D204, C305 and L202 on the PLL unit. Signals passed through the bandpass filters are applied to the first RF amplifier, Q201 and are amplified.

Output signals from Q201 are again passed through bandpass filters which consist of L203, C209, D205, D206, L204, C212, D207, D208, D209, D210, L205 and C216 and are then reduced interference from out-of-band signals.

Diodes D201 to D210 are varactor diodes that track the bandpass filters and are controlled by the PLL lock voltage. These diodes tune the center frequency of the bandpass filters for wide bandwidth reception and a good image response rejection ratio.

Signals from the bandpass filters are fed into gate 1 of Q202. Local oscillator signals from the PLL unit also are fed into gate 2 of Q202 through C217. Q202 is a first mixer which converts RF signals into 21.8MHz the first intermediate frequency and outputs it at L206.

5 - 1 - 3 INTERMEDIATE FREQUENCY CIRCUIT

The first intermediate signal from L206 is filtered further from out-of-band interference through a matched pair of monolithic crystal filters that are FI201 and is then amplified at Q203 and Q204.

IC102 on the MAIN unit incorporates in one package a second local oscillation circuit, a second mixer, a limiter amplifier, an active filter, and a quadrature detector circuit.

The first intermediate frequency signal enters IC102 (pin 16) and mixes with a second local oscillator frequency (21.345MHz) generated by X101. The 455kHz second intermediate frequency signal is then output from pin 3. This signal passes through a high-performance ceramic filter (FI101), and is amplified at a limiter amplifier.

Output signals from the limiter amplifier are separated. One of the signal enters a quadrature detector circuit, and the other exits from pin 7. The signal output from pin 7 enters pin 8 through ceramic resonator X102, and then both signals are detected at a quadrature detector circuit inside IC102. The resulting audio signal is output from pin 9 and is then applied to IC706 (pin 29) on the LOGIC unit.

5 - 1 - 4 AUDIO FREQUENCY CIRCUIT

IC706 incorporates a CTCSS encoder/decoder, an AF amplifier, and a dual AF filter circuit.

The signal applied to IC706 is amplified and then exits from pin 18. This signal is amplified at Q702 through a low-pass filter consisting of R715 and C711. This low-pass filter is a de-emphasis circuit which has -6dB/oct characteristics.

Output signals from Q702 re-enter the MAIN unit and are fed into AF SWITCH (Q120). This FET cuts the AF signal when RX MUTE is operating or the squelch is closed.

The signals that enter Q120 are then fed into an AF power amplifier circuit (IC103 pin 3) through AF volume control R161. The gain of IC103 is fixed by R162 and C155 which are connected across pins 1 and 8. The speaker is driven at more than 500mW of AF output by IC103 with an 8 ohm load and 8.4V Vcc.

The power source for IC103 consists of Q123 and D113 which protect it from excess voltage, maintaining the voltage at less than 12V.

5 - 1 - 5 SQUELCH CIRCUIT

A portion of signals output from IC102 (pin 9) pass through R148, Squelch volume and is then input to active filter IC101B (pin 2) where noise signals are selected at approximately 20kHz then output from pin 1.

The noise signals are detected by D110 and are then converted to DC voltage and used as squelch control signals. This voltage is input to IC703 (pin 15) on the LOGIC unit through inverter circuit Q119, and is then output from pin 30 as R.Mute voltage.

R.Mute voltage is applied to the gate of Q120 and switches AF output. Q120 also eliminates the noise from channel changing during operation. Q126 receives a strobe pulse from IC703 and applies a mute signal to Q120.

5 - 1 - 6 FIRST LOCAL OSCILLATOR CIRCUIT

The signal (114.2 ~ 152.2 MHz) generated at the VCO is amplified at Q207 on the PLL unit and is then input to gate 2 of Q202 on the RF unit through D214.

5 - 2 TRANSMITTER CIRCUITS

5 - 2 - 1 MIC AMPLIFIER CIRCUIT

The audio signal from MIC 1 or MIC 2 is amplified by a limiter amplifier circuit consisting of Q101 to Q104. This limiter amplifier circuit employs of a negative feedback circuit that has pre-emphasis characteristics between 300Hz and 3kHz with 6dB/oct.

The first mic amplifier circuit consists of a differential amplifier circuit that makes a limiter output signal in a symmetrical wave form.

The output signal from the limiter amplifier is like a square wave and includes many RF signals which are fed back from the transmitter's final stage. The output signal, therefore, is fed to splatter filter circuit IC101A which reduces signals with more than 3kHz, and then applies it to the VCO for modulation.

5 - 2 - 2 BUFFER AMPLIFIER CIRCUIT

The 100MHz band is generated by the VCO and is buffered and amplified at Q207 and Q223. Output from Q223 is amplified at drive stage Q208 through D215, thus obtaining a wideband of 20mW.

5 - 2 - 3 POWER AMPLIFIER CIRCUIT

IC201 is a small-sized power module giving a stable output power of more than 5W (136 ~ 144MHz or 148 ~ 174MHz) with a driving power of 20mW from Q208.

The driving signals from Q208 are fed into IC201 (pin 1), amplified up to approximately 5W at 13.2V, and are output from pin 5.

While transmitting, Q220, D218 and D219 are activated, then L217 and C265 become parallel resonance circuits. The output power from IC201 is applied to the antenna terminal through a low-pass filter consisting of C226 to C270, L218 and L219 that filters and reduces harmonic spurious radiation.

Q206 controls the bias voltage of Q208 and IC201 to prevent unwanted emissions when switching from receive mode to transmit mode, or when the PLL is being unlocked to prevent a possible failure.

5 - 2 - 4 APC CIRCUIT

The antenna mismatching detection circuit consists of L215, C256 to C261, D216 and D217. Output voltage of the detector is a minimum value when the antenna impedance is matched at 50 ohms. However, when the antenna impedance is in a mismatched condition, the detector voltage becomes higher than it would be if the antenna were matched.

Q218 and Q219 make up the differential amplifier circuit. At the base of Q219, the bias voltage determined by R272, R276 and R274 is applied.

The voltage detected at D216 and D217 is combined by R237 and R238, and is fed into the base of Q219. If a mismatched condition occurs, the voltage at the base of Q218 will be higher than at the base of Q219. This condition will reduce the Q217 collector current and the Q216 base current, decreasing the current of Q208.

The output power of Q208 is also decreased, reducing the output power of IC201 until the base voltage of Q218 becomes equal to the base voltage of Q219.

In a matched condition, HIGH output power is determined by the value of R272. When the power switch is in the LOW position, the combination of R273 and R275 is connected in parallel with R274. R275 may then be used to set the low power.

5 - 3 PLL CIRCUITS

The PLL is designed in a way that allows the desired frequency to be generated directly by the VCO, adopting a dual modulus pre-scaler system. The PLL consists of a pre-scaler (IC203) and PLL IC (IC202). It is fed "divided by N-data" from the MPU which determines the operating frequency.

N-data is determined by dividing the desired frequency by the reference frequency. Desired frequency is the transmit frequency in the transmit mode and the first local oscillator frequency in the receive mode.

$$N = \frac{\text{Desired frequency}}{\text{Reference frequency}}$$

A reference frequency of 5kHz (12.5kHz #03) is obtained by oscillator Q215, X201 and the internal IC202 divider.

Signals from the VCO that are buffer amplified at Q207 are divided N times at IC203 and fed into pin 4 of IC202. Signals inside IC202 are phase detected and are lock voltages that are output from pins 12 and 13. Output voltages are applied to varactor diode D211 and D212 in the VCO circuit through a loop filter that controls the VCO frequency. Due to a no-multiplying mixing circuitry, the circuit constitution is simple and reduces spuriousness.

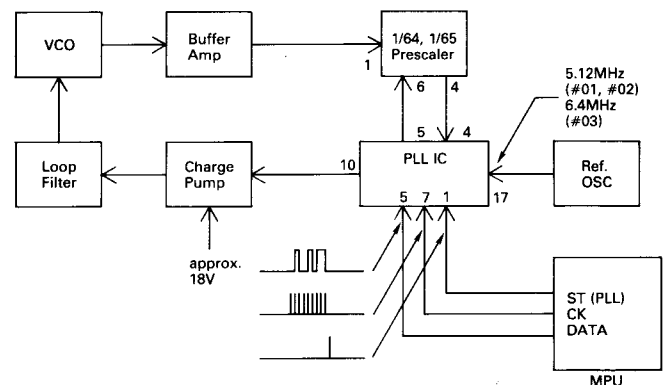

Fig. 5-1 PLL Circuit Block Diagram

5 - 3 - 1 UNLOCK CIRCUIT

When the PLL is unlocked, pin 10 of IC202 is at a LOW voltage level. This voltage is fed into unlock detection circuits Q121 and Q124 on the MAIN unit and is then sent to the MPU on the LOGIC unit.

5 - 3 - 2 LOOP FILTER CIRCUIT

Output from pins 12 and 13 on the IC203 is fed into charge pumps, Q212 and Q213 and is then applied to a lag lead-type loop filter that consists of R248, R246, and C278. These circuits determine the characteristics of the PLL.

Output voltages from loop filter control varactor diode D211 and D212 in the VCO circuit through integral circuits R245 and C276.

5 - 3 - 3 VCO UNIT

The VCO, Q205 employs a Hartley oscillator circuit. The VCO free-run frequency is shifted by induction reactance of L221 which is changed by Q222 and D213, and is then controlled by a varactor diode. Thus a stable oscillation is achieved over a wide frequency range.

While receiving, the RS5 line is 5V, Q222 and D213 are activated, and then C236 is connected in a parallel with D211 and D212 through C233. While transmitting, the RS5 line is 0V and then Q222 and D213 turn OFF. So C236 has no effect on the oscillation frequency. Therefore the VCO free-run frequency while transmitting is higher than while receiving.

While transmitting, modulation signals are applied to the cathode of D211 and D212, and then its capacitance is changed, performing frequency modulation. This deviation is adjusted by R186.

5 - 4 POWER SUPPLY CIRCUITS

5 - 4 - 1 INTERNAL/EXTERNAL POWER

When using a battery pack, RL101 is OFF. When a power source having 10 ~ 16V is connected to the external power terminal (EXT), RL101 will be activated. The transceiver will then be operated by an external power source.

If an incorrect connection to the external power terminal (such as reversing polarities) is made, D109 will be affected, reversing its bias and preventing RL101 from being activated.

5 - 4 - 2 +5V REGULATOR CIRCUIT

The +5V voltage regulator circuit consists of Q117, Q118 and D107 where output voltage is kept at 5V constantly, even with input voltage from 5.1 ~ 16V. These transistors are connected in a complementary circuit in order to acquire a higher current amplification factor. As the temperature coefficient of the junction voltage of D108 is nearly equal to the voltage of Q117 V_{BE} , the output voltage is kept constant against temperature changes.

5 - 4 - 3 5V REGULATOR, POWER SAVE CIRCUIT

This voltage regulator circuit uses reference voltage from pin 29 of IC703 on the LOGIC unit. This circuit consists of Q115 and Q116 which are also connected in a complementary circuit in order to stabilize operations.

When the power save function is activated, power save signals from pin 29 of IC703 on the LOGIC unit are applied to Q115 at intervals, thus Q115 turns ON and OFF alternately. The result is that the power save signal controls +5V and constructs the POWER SAVER.

5 - 4 - 4 T/R SWITCHING CIRCUIT

While transmitting, Q106 is activated and transfers transmit signals to the MPU. At the same time, Q107, Q108, and Q109 are also activated, and Q110 turns OFF. Q113 and Q114 are T5 voltage regulator circuit that is switched by Q109. When Q109 is activated, the T5 line operates at 5V and the R5 line at 0V. While receiving, Q106 is OFF. Q109 is then OFF and Q110 is ON, resulting in the T5 line being 0V and the R5 line 5V.

When the squelch is changed from the closed to open condition some noise will be emitted from the speaker. This phenomenon is called the squelch burst. To remove this noise from the speaker, the squelch can be controlled by a CTCSS tone.

The transmitter contains a delay circuit for the transmit carrier. The delay period for the transmit carrier is longer than that of the PTT.

In this transceiver the delay circuit consists of time constants C131 and R137 which remove the squelch burst.

5 - 4 - 5 VOX POWER SOURCE CIRCUIT

This is a current limiter that supplies a voltage to the external VOX unit, HS-10SA. Current drain of up to 5mA is acceptable. In the case of a normal load current the voltage drop through R279 is small, approximately 5V, and is fed into the VOX unit. The increase in load current leads to the increase of the voltage drop at R279. When the voltage, obtained by adding the voltage between the emitter and base of Q221 to it, is equal to the voltage between R280 and the D225 cathode, the load current is limited.

This VOX power source circuit is also a data transmit circuit when the cloning operation is activated. The base of Q217 connects through R281 to pin 28 (CPO) on IC703. CPO is the output port for cloning data and controls Q217, thus data is transferred to existence.

Cloning data exits from the mic terminal and passes through R102, R104, and control Q106 on the MAIN unit. It then enters pin 14 (SEND) of IC703 for data reception. SEND also combines a data input port.

5 - 5 LOGIC CIRCUITS

The LOGIC circuits consist of an 8 bit C-MOS MPU, a 2K C-MOS RAM, a CTCSS tone encoder/decoder, and an LCD driver. They control frequency, tone, display, etc.

5 - 5 - 1 MPU

This MPU, μ PD78C06AG, includes a 4K byte ROM and a 128 byte RAM. Following is an explanation of operations related to each port.

(1) DB 0 ~ DB 7

These are bi-directional ports, and are an 8 bit data bus. The bus transfers or receives the data to and from a 2K RAM IC chip. DB 0 to DB 3 are also used for matrix reception.

(2) PE 0 ~ PE 15

These are 16 bit ports which have address ports and output ports that are switched by the program. PE 15 is used to select signals. PE 0 to PE 10 generate address signals. PE 0 to PE 3 and PE 14 are output ports for the matrix. PE 0 is used as a switching signal for command and LCD driver data. (The matrix construction is described in Fig. 5-2.)

(3) PORTS A

These are output ports with an 8 bit latch.

- PA 7 (\overline{CS})

This is an enable signal for the LCD driver. When this port is LOW, the MPU transfers COMMAND or DATA to the LCD. (Timing charts is described in Fig. 5-3.)

- PA 4 (TMUT)

This is an output port and will be at the HIGH level position for approximately 60 milliseconds when changing from receive to transmit. If the PLL is unlocked then this port will remain at a HIGH level.

- PA 3 (RMUT)

This port will be at the HIGH level position when receiving in the mute condition.

- PA 2 (PSAU)

This port outputs control signals for saving power. When this port is in the LOW level position, the transceiver is in the save condition.

- PA 1 (CPO)

This port outputs cloning data. (The cloning data construction is described in Fig. 5-4.)

- PA 0 (STRB)

This port outputs latch signals for PLL data.

(4) PORTS B

These ports are 8 bit bi-directional ports that change in 1 bit steps.

- PB 7 (\overline{MONI})

This is an input port for the monitor switch.

- PB 6 ($\overline{T/R}$)

This is an output port for switching the signals of the TONE IC. While in the transmit mode, this port is at the LOW level position; in the receive mode it is in the HIGH level position. However, if the TONE number is 0, voltage signals are opposite.

- PB 0 ~ 5 (S0 ~ S5)

These are output ports for TONE data which describe TONE numbers, frequency, and data.

(5) PORTS C

These are input ports with 6 bits of data.

- PC 5 (\overline{BUSY})

This is an input port for BUSY signals from the LCD driver.

- PC 4 (TRF)

This is a T5V input port. When this port is at the HIGH level position the TX indicator is illuminated.

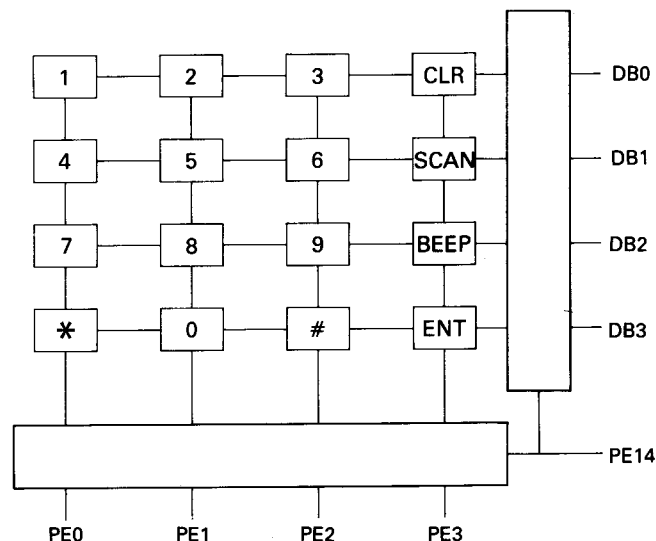
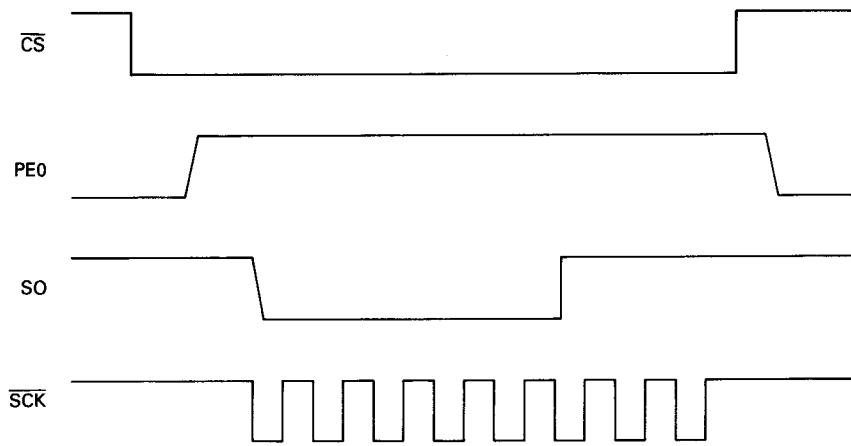

Fig. 5-2 Matrix Construction

AT COMMAND TRANSMITTING (CODE 0E, 0H)



AT DATA TRANSMITTING (DATA 0A, 5H)

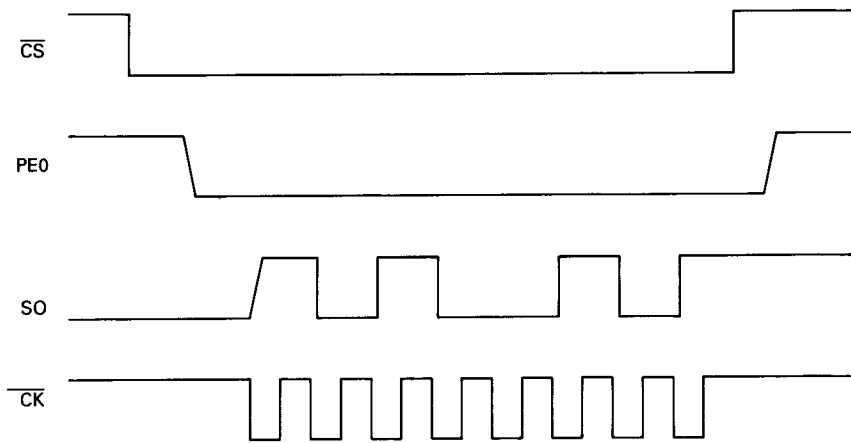

Fig. 5-3 Timing Chart of COMMAND and DATA

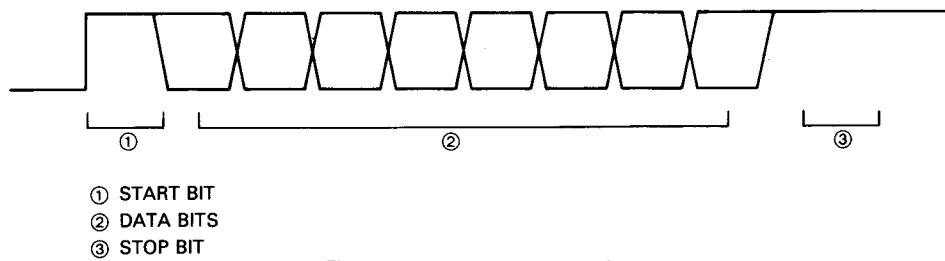

Fig. 5-4 Cloning Data Construction

- **PC 3 ($\overline{\text{FUNC}}$)**

This is an input port of the function switch. When the function key is pressed, this port is at the LOW level position and the secondary functions of the keyboard can be selected.

When this port is in the LOW level position while power switched ON, the MPU is in the receive mode of cloning.

- **PC 2 ($\overline{\text{SEND}}$)**

This is a T/R switching signal input port. When this port is in the HIGH position the MPU is in transmit mode. The port is also used to input cloning signals.

- **PC 1 ($\overline{\text{SQL}}$)**

This is an input port for squelch signals. When the squelch is open, this port is in the HIGH level position.

- **PC 0 ($\overline{\text{UNLK}}$)**

This is an input port for unlocked signals. When the PLL is unlocked, this port is at a LOW level position.

(5) SERIAL PORTS

- **SO**

This is an output port of the shift register inside the MPU. It outputs N-data, LCD commands, and LCD data.

- **$\overline{\text{SCK}}$**

This port outputs timing signals of data for transfer to the SO port. SO is altered by the trailing edge of the $\overline{\text{SCK}}$ signal.

(6) OTHERS PORTS

- **INT 0**

This is an input port for detector signals of the TONE IC. When this port is at the HIGH level position the CALL indicator is illuminated.

- **INT 1**

This is an input port for stand-by signals. When the power switch is OFF this port is in the HIGH level position. The LCD then is not illuminated and each port is initialized.

- **TO**

This port outputs a BEEP sound.

- **$\overline{\text{RD}}$**

This port outputs timing signals when the MPU receives data (reading) to the RAM IC chip.

- **$\overline{\text{WR}}$**

This port outputs timing signals when the MPU transfers data from (writing) the RAM IC chip.

5 - 5 - 2 RAM

μPD446C is a 2048 word 8 bit C-MOS RAM IC chip. This RAM memorizes operating channels, PLL T/R N-data, TONE numbers, shift frequencies, TONE-data tables, etc. The data are written or read to addresses which are selected by PE 0 to PE 10 of the MPU. Writing and reading timing depend on ports $\overline{\text{RD}}$ and $\overline{\text{WR}}$.

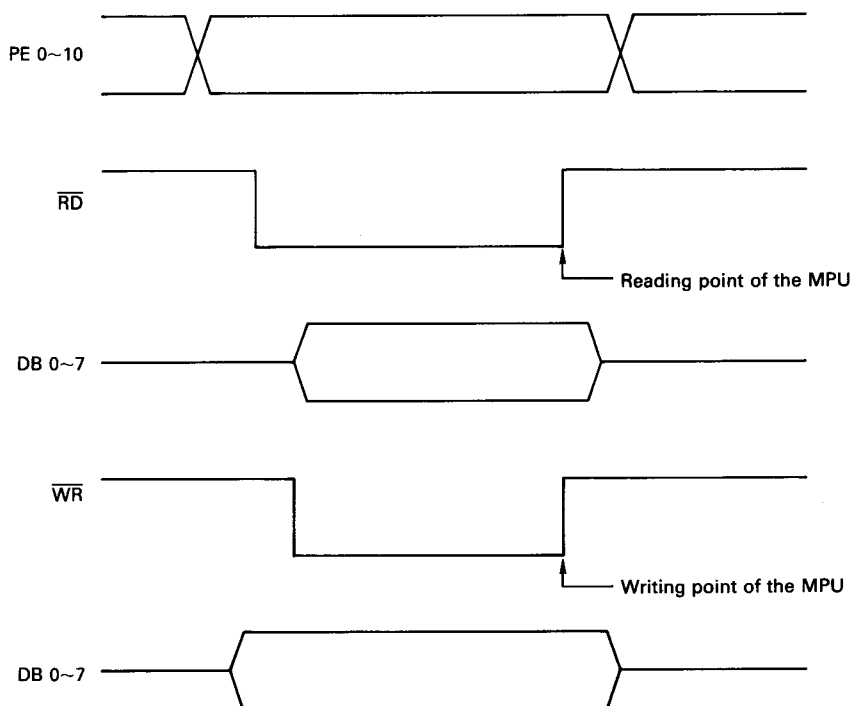

Fig. 5-5 Timing Chart of Memory Reading/Writing

5 - 5 - 3 RESET CIRCUIT

After the circuit is switched ON, the +5V line becomes 5V and Q703 is activated. The collector of Q703 thus is at the HIGH level position. Pin 12 of IC704E is in the LOW level position and pin 10 of IC704D is changed from LOW level to HIGH. The result is that the MPU and the LCD driver are reset.

At the time the power switch is turned off, Q703 also is OFF. Pin 12 of IC704E then is in the HIGH position and is applied to INT 1 of the MPU, resulting the MPU becomes stand-by operate.

5 - 5 - 4 DISPLAY CIRCUIT

IC602, in the DISPLAY unit is the LCD driver, and segments on the LCD are displayed with 1/2 bias and 1/2 duty conditions. The bias voltage is generated via the dividing resistor which consists of R605, R606 and R607. Output from CM1, CM2, and S0 to S31 on the IC601 drive the LCD segments.

5 - 5 - 5 DTMF CIRCUIT

IC602, the DTMF encoder, generates tone signals that match DTMF telephone dialing tones. While transmitting, Q704 will be activated, thus sending voltage to IC602 and to the CONT of IC603.

When there is input from the keyboard, the proper frequency dividing ratio which divides X601 is selected to output a set of audio frequencies.

5 - 5 - 6 CTCSS CIRCUIT

IC706 generates 37-type tones of programmable CTCSS encoder/decoder. When a tone number is set, data is sent to encoder/decoder. When a tone number is set, data is sent to IC706 from the MPU (S0 ~ S5). The \bar{T}/R port is a switching port for transmitting and receiving for IC706. When this port is in the LOW position, IC706 is in the transmit mode, and when the port is in the HIGH position IC706 is in the receive mode. However, while transmitting with tone number 0, the \bar{T}/R port of IC703 is in the HIGH position, and thus no tone signal is output from IC706.

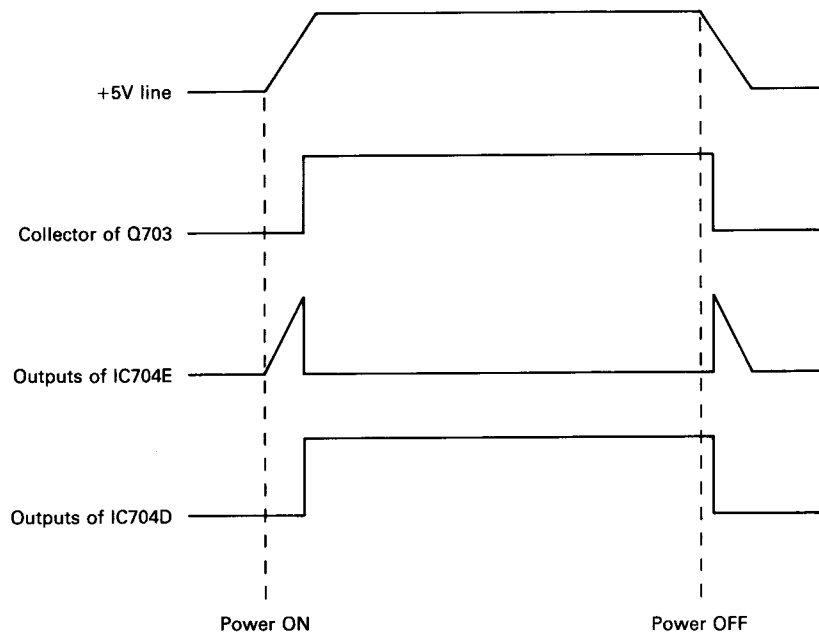
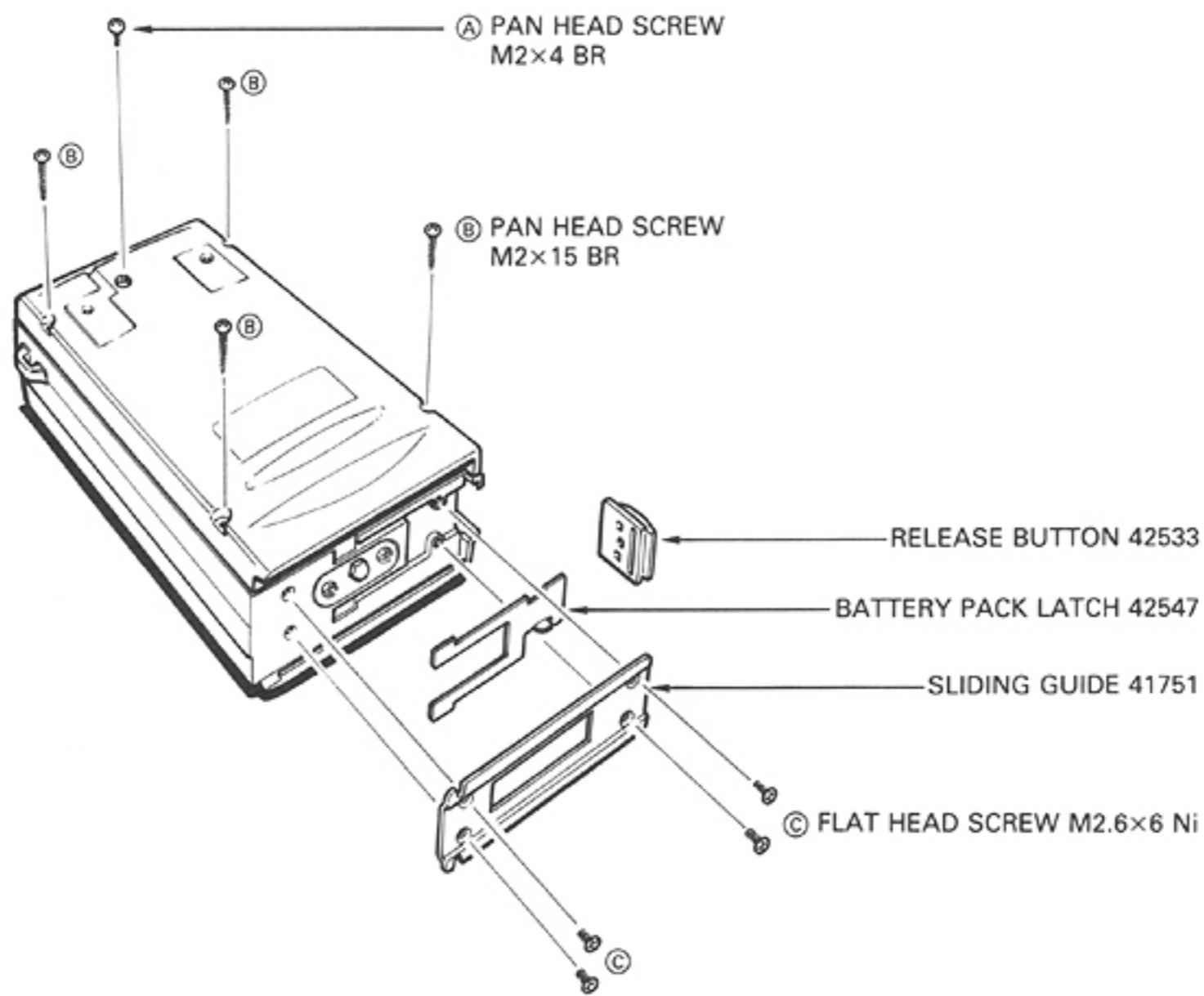

Fig. 5-6 Reset Timing Chart

SECTION 6 MECHANICAL PARTS AND DISASSEMBLY

6 - 1 DISASSEMBLY OF THE CASE

1. Turn the POWER SWITCH OFF and remove the battery pack.
2. Remove screw (A) and four screws (B) on the rear panel, and four screws (C) on the bottom as shown in the figure.



3. Remove the rear panel as shown in the figure.

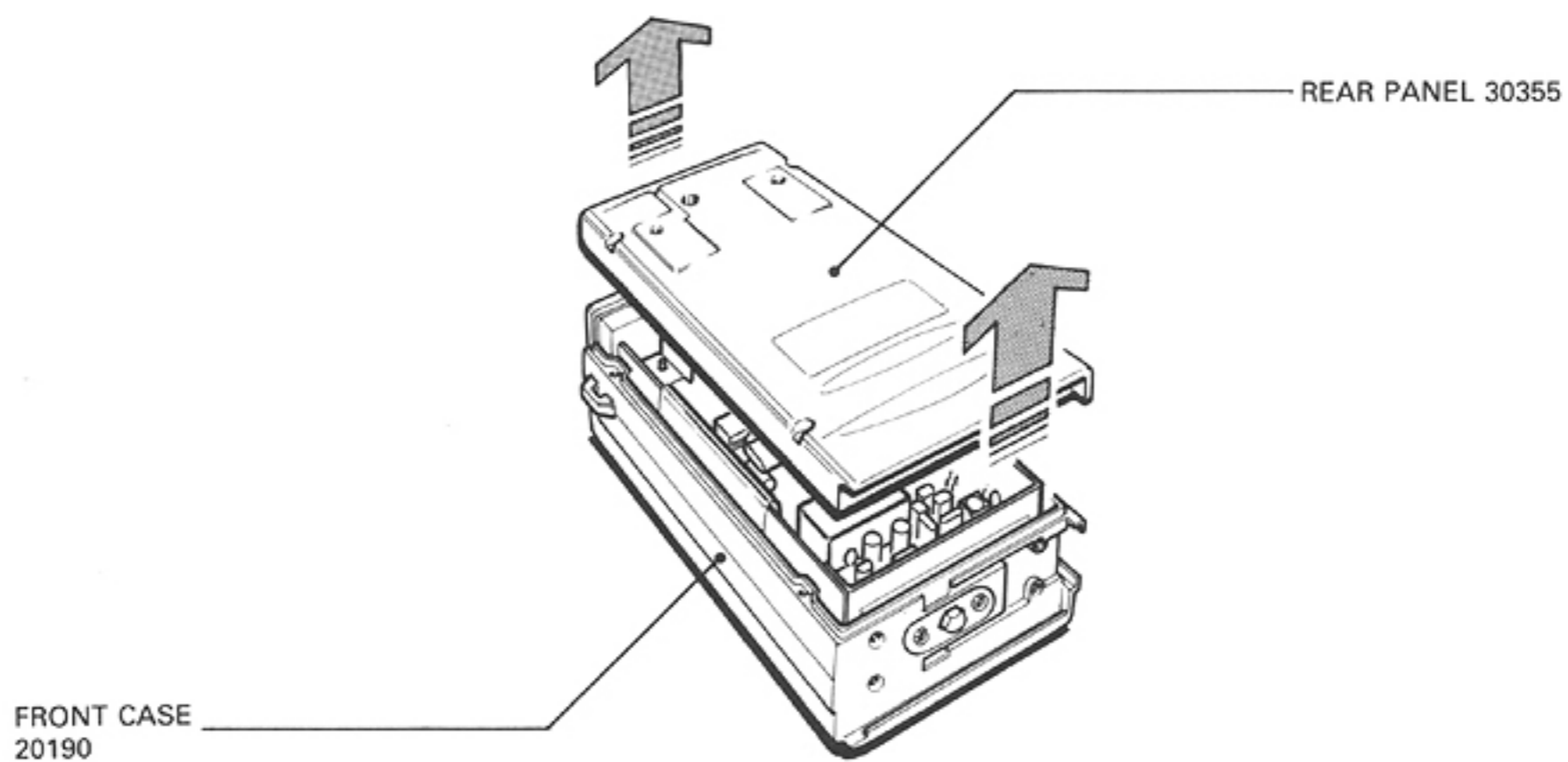

- Slide the inner frame upward slightly as shown in the figure, and lift the frame away from the front cover. At this time, be careful not to damage the flexible board.

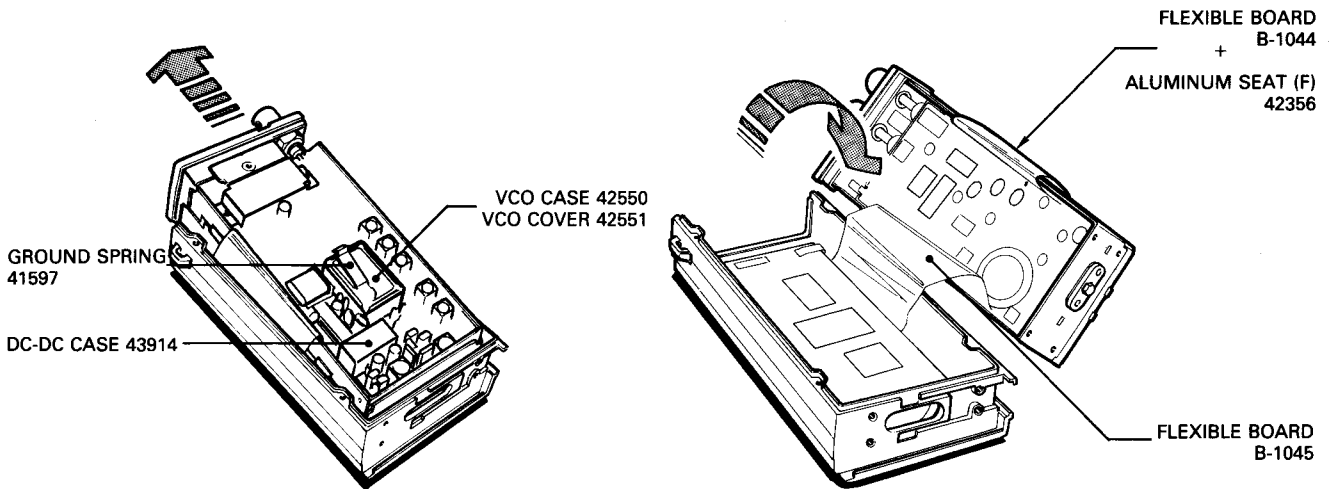

- To open the chassis, remove the two knobs on the top panel (VOLUME and SQUELCH) and press IN the MONITOR and HIGH/LOW buttons. After unscrewing the four screws on the sides of the chassis, open the chassis as shown in the figure.

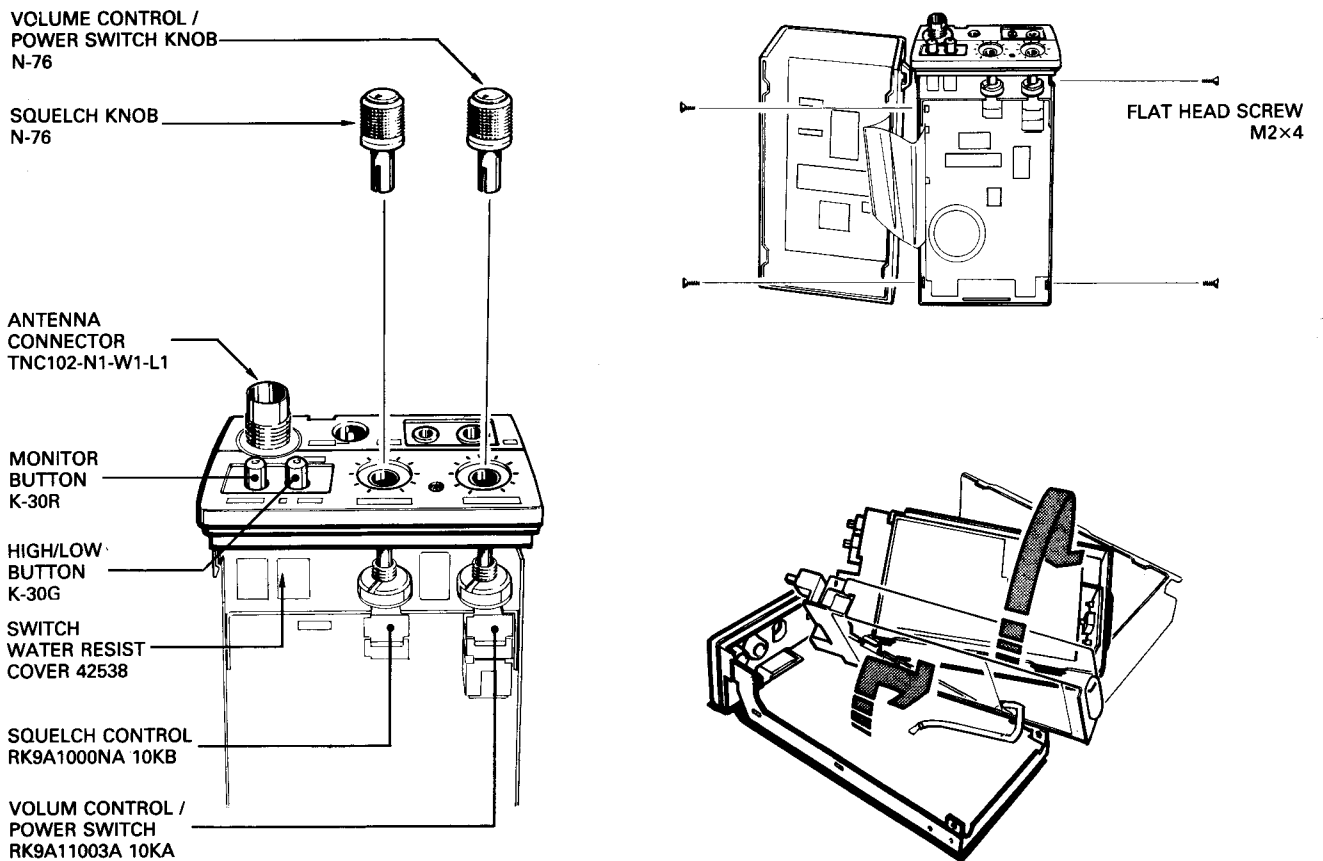

6 - 2 DISASSEMBLY OF THE TOP PANEL

1. Remove the screw (A).
2. Remove the TNC-NUT and the TNC-WASHER.
3. Remove the ANTENNA CONNECTOR by unsoldering point (B) on the parts side and point (C) on the soldering side of the PLL board.
4. Remove the TOP PANEL by slightly prying outward on both sides tabs (points (D)) of the TOP PANEL.
See the diagram below. Be careful not to break the tabs.

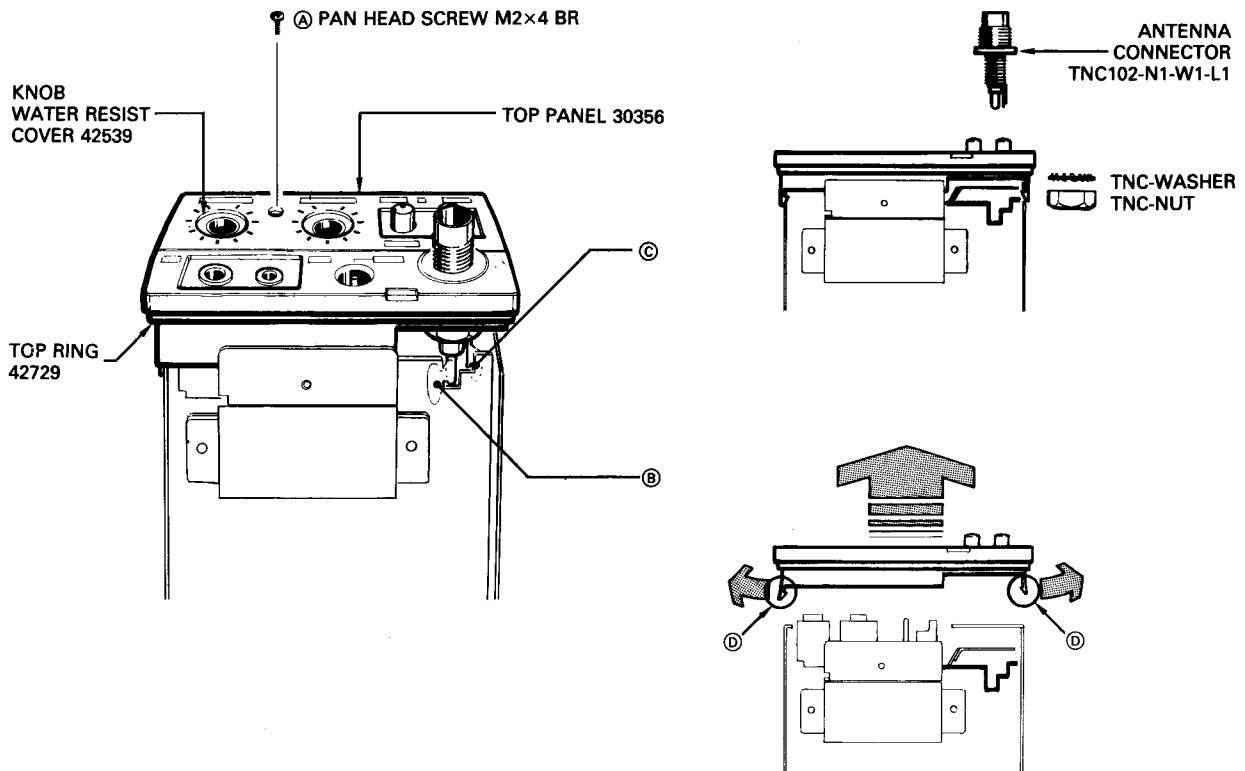

6 - 3 PA AND EXTERNAL JACK ASSEMBLY

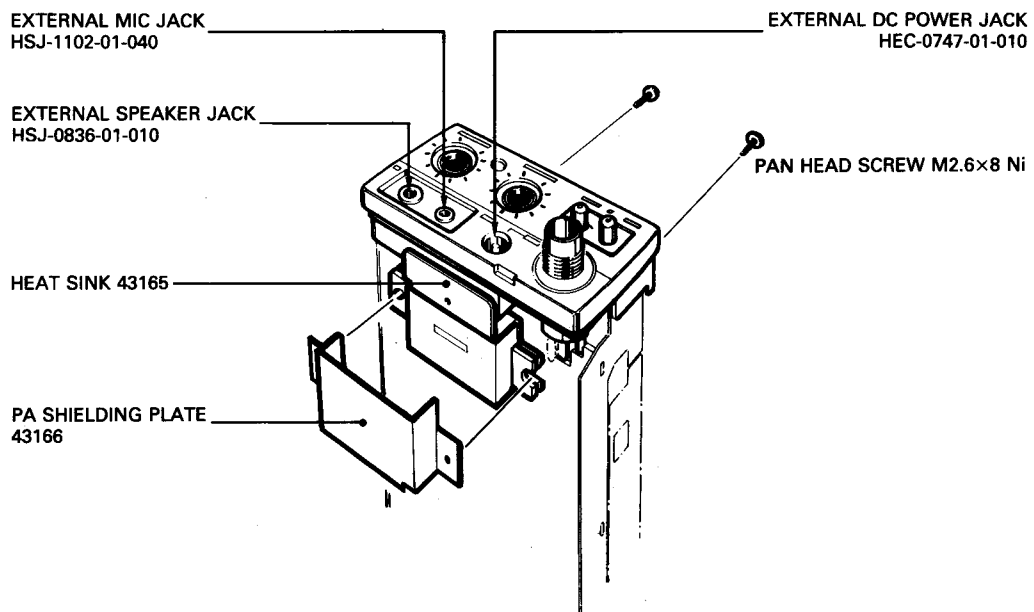

6 - 4 SPEAKER AND MICROPHONE ASSEMBLY

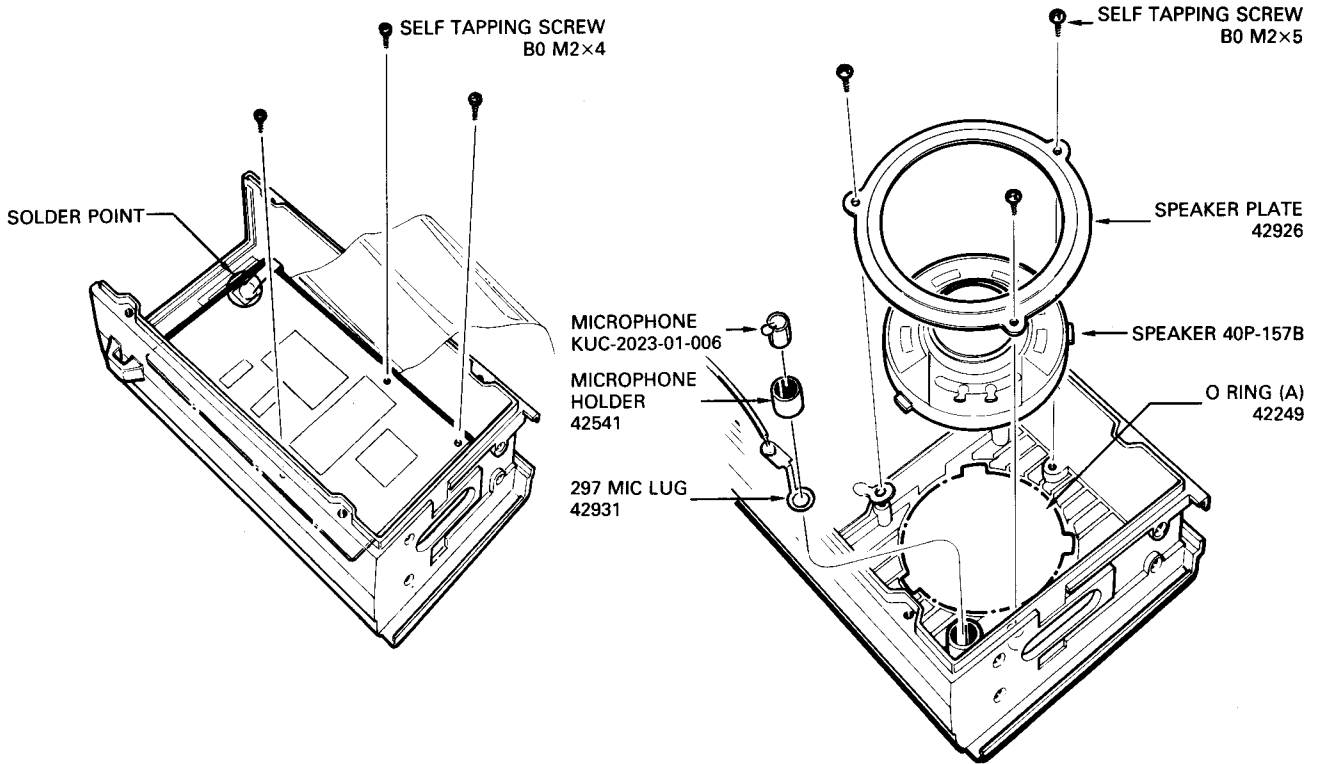

6 - 5 DISPLAY UNIT AND LCD ASSEMBLY

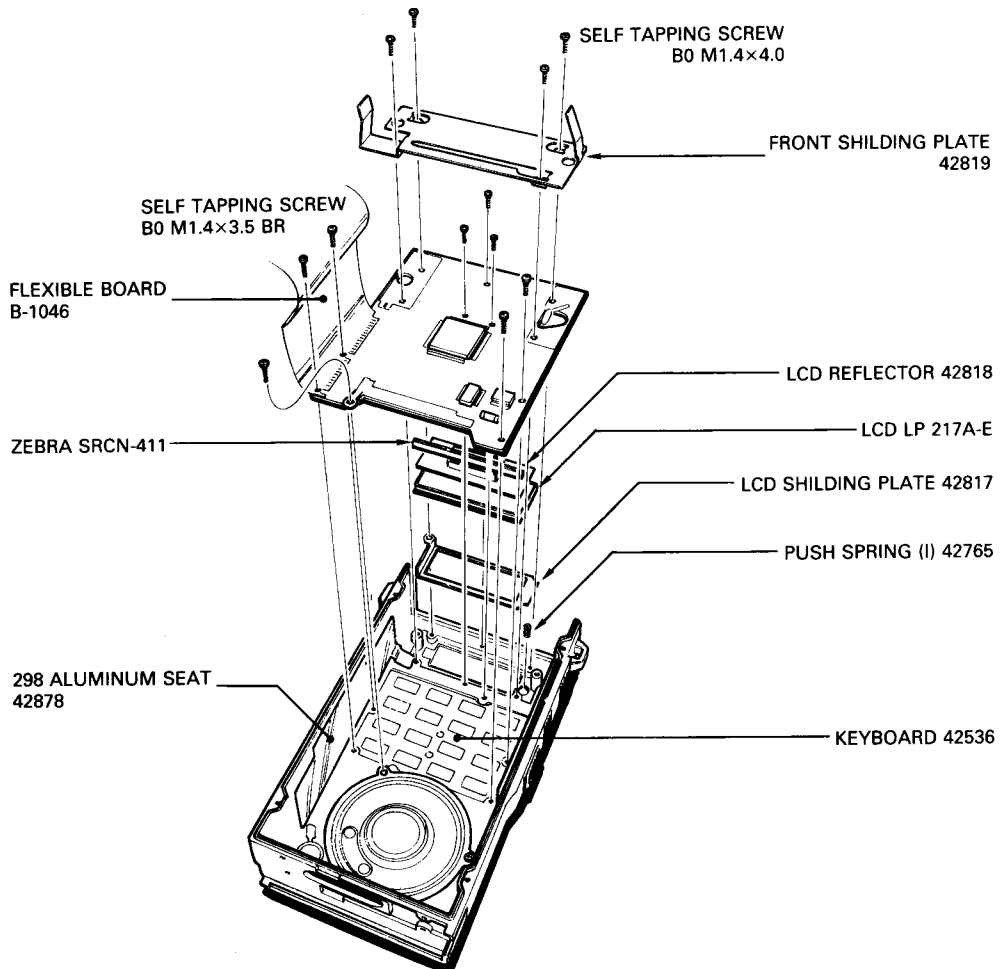

6 - 6 PTT SPRING ASSEMBLY

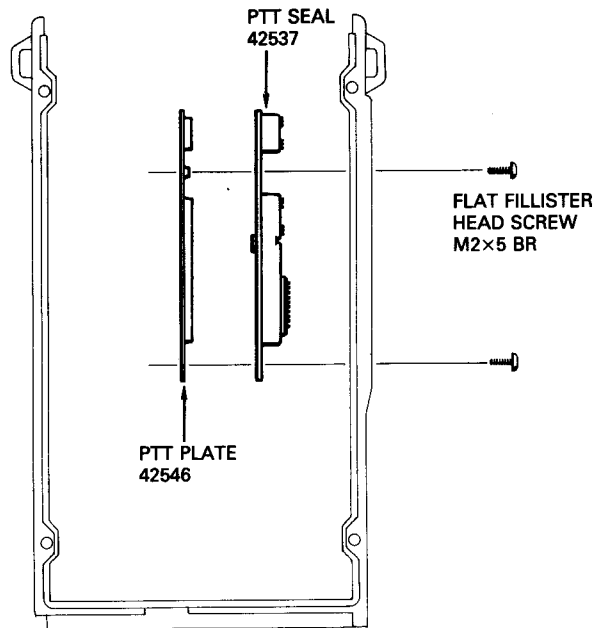

6 - 7 UNIT BOTTOM ASSEMBLY

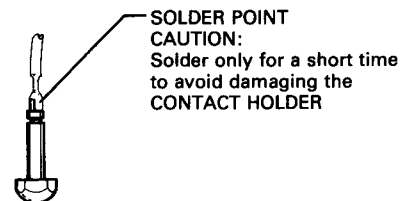
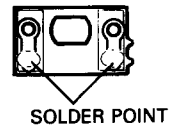
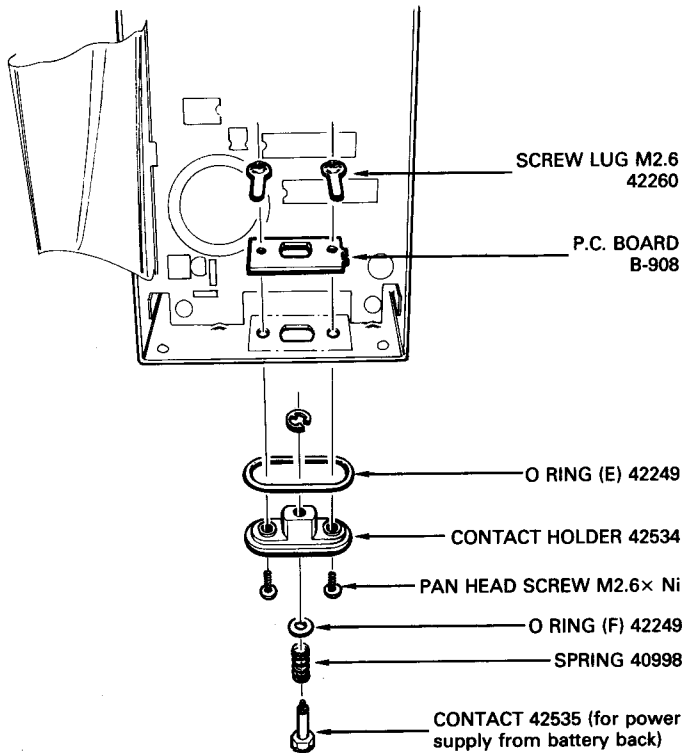

SECTION 7 MAINTENANCE AND ADJUSTMENT

7 - 1 PREPARATION BEFORE SERVICING

1. Detach the power cord and turn OFF the power switch before performing any work on the transceiver.
2. Do not short circuit components while making adjustments.
3. Use an insulated tuning tool for all adjustments.
4. Do not force any of the variable components. Tune them slowly and smoothly.
5. Follow the instructions exactly. If an indicated result is not obtained, repeat the instruction until the correct result is obtained.
6. Check the condition of connectors, solder joints and screws when adjustments are complete. Confirm that components do not touch each other.
7. There are several versions of this transceiver. Adjustment procedures and results may differ for each version. Be certain to follow the correct procedure for the transceiver you have.
8. Confirm defective operation of the transceiver first when checking an out-of-service unit. Verify that external sources do not cause the problem.
9. Use the correct tools and test equipment.
10. Remove the transceiver case as shown on Page 6-1.
NOTE: Do not damage the flexible printed circuit when removing the case.
11. Remove the four screws to open the hinged chassis as shown on Page 6-2.
12. For transmission problems, attach a dummy load to the antenna connector. For reception problems, attach an antenna or signal generator to the antenna connector. Do not transmit into the signal generator.
13. Recheck for the suspected malfunction with the power switch on.
14. Check the defective circuit. Measure the DC voltages of the collector, base and emitter of each transistor.
15. It is convenient to short circuit an accessory mic connector plug and insert it into the microphone jack when troubleshooting the transmitter.

7 - 2 POWER SUPPLY CHECKES

INSTRUMENTS REQUIRED		CONNECTIONS					
(1) VOLTAGE REGULATED POWER SUPPLY • OUTPUT VOLTAGE : DC 13.2V • CURRENT CAPACITY : 2A							
(2) RF POWER METER (TERMINAND TYPE) • MEASURING RANGE : 0~5W • FREQUENCY MINIMUM : AT LEAST 180MHz • IMPEDANCE : 50 Ω • SWR : LESS THAN 1:1.2							
(3) VOLTMETER • INPUT IMPEDANCE : 50k Ω/V DC OR BETTER							
ADJUSTMENT	ADJUSTMENT CONDITIONS	MEASUREMENT			VALUE	ADJUSTMENT POINT	
		UNIT	LOCATION	UNIT		ADJUST	
+5V	1	• Receive mode	MAIN	See diagram	5V		Verify
R5	1	• Receive mode	MAIN	See diagram	5V		Verify
PSAV	1	• Receive mode	MAIN	See diagram	5V		Verify
UNLK	1	• Receive mode	MAIN	See diagram	5V		Verify
T5	1	• Transmit mode	MAIN	See diagram	5V		Verify
+5	1	• Receive mode	MAIN	See diagram	5V		Verify

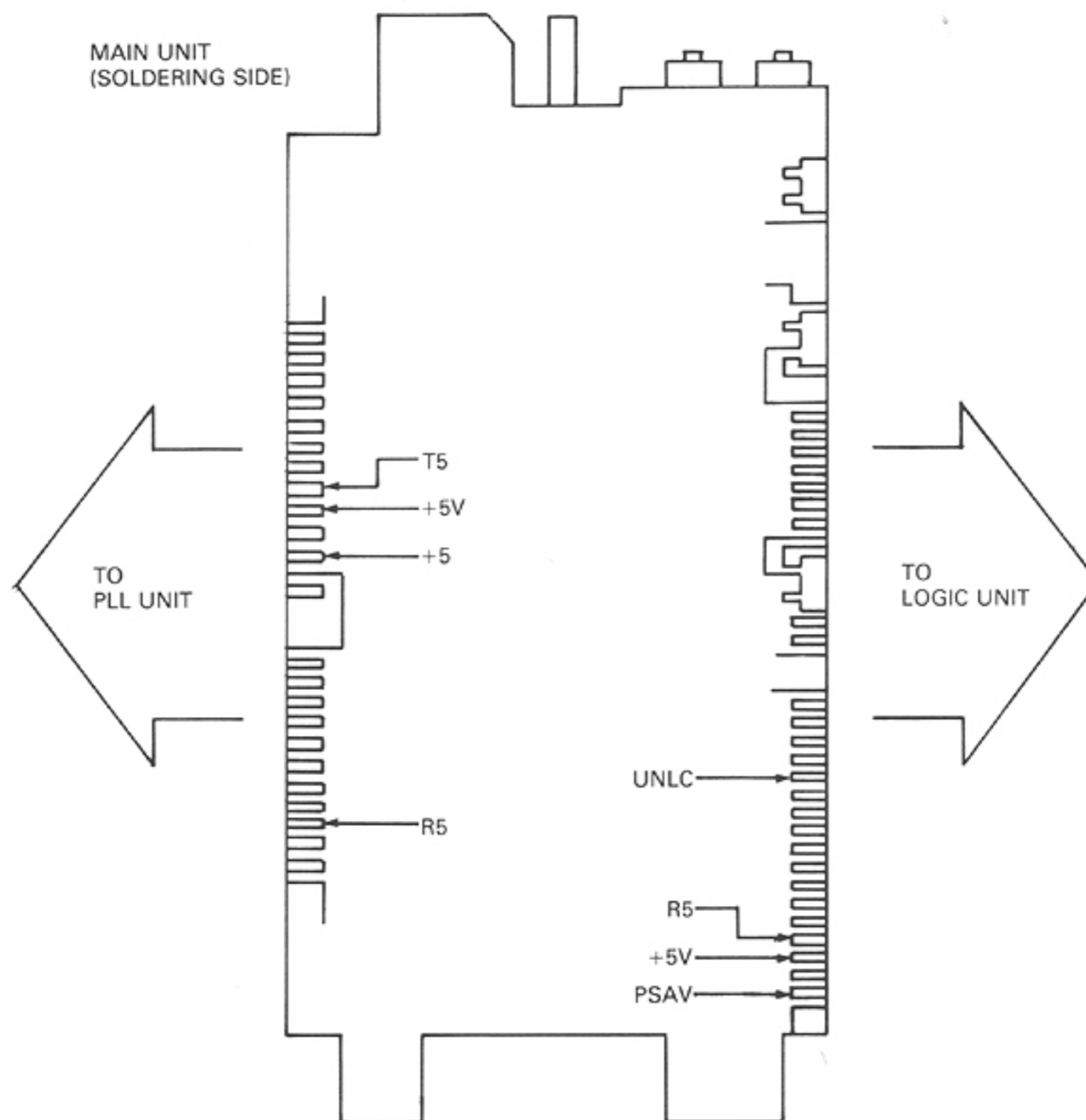

7 - 3 PLL ADJUSTMENT

INSTRUMENTS REQUIRED		CONNECTIONS					
(1) VOLTAGE REGULATED POWER SUPPLY ● OUTPUT VOLTAGE : DC 13.2V ● CURRENT CAPACITY : 2A (2) RF POWER METER (TERMINAND TYPE) ● MEASURING RANGE : 0~5W ● FREQUENCY MINIMUM : AT LEAST 180MHz ● IMPEDANCE : 50 Ω ● SWR : LESS THAN 1:1.2 (3) VOLTMETER ● INPUT IMPEDANCE : 50k Ω/V DC OR BETTER (4) FREQUENCY COUNTER ● FREQUENCY RANGE : AT LEAST 180MHz ● ACCURACY : BETTER THAN ±1PPM ● SENSITIVITY : 100mV OR BETTER							
ADJUSTMENT	ADJUSTMENT CONDITIONS	MEASUREMENT			VALUE	ADJUSTMENT POINT	
		UNIT	LOCATION	UNIT		ADJUST	
LOCK VOLTAGE	1	PLL	Connect a voltmeter between R248 and GROUND.	4.0V (#01, #03) 2.0V (#02)	PLL	L221	
	2	PLL		bellow 16V	Verify		
REFERENCE FREQUENCY	1	PLL	Connect a frequency counter to cathode of D214.	126.200 MHz (#01, #03) 114.200 MHz (#02)	PLL	C288	
	2			174.00 MHz (#01, #03) 144.00 MHz (#02)	Verify		

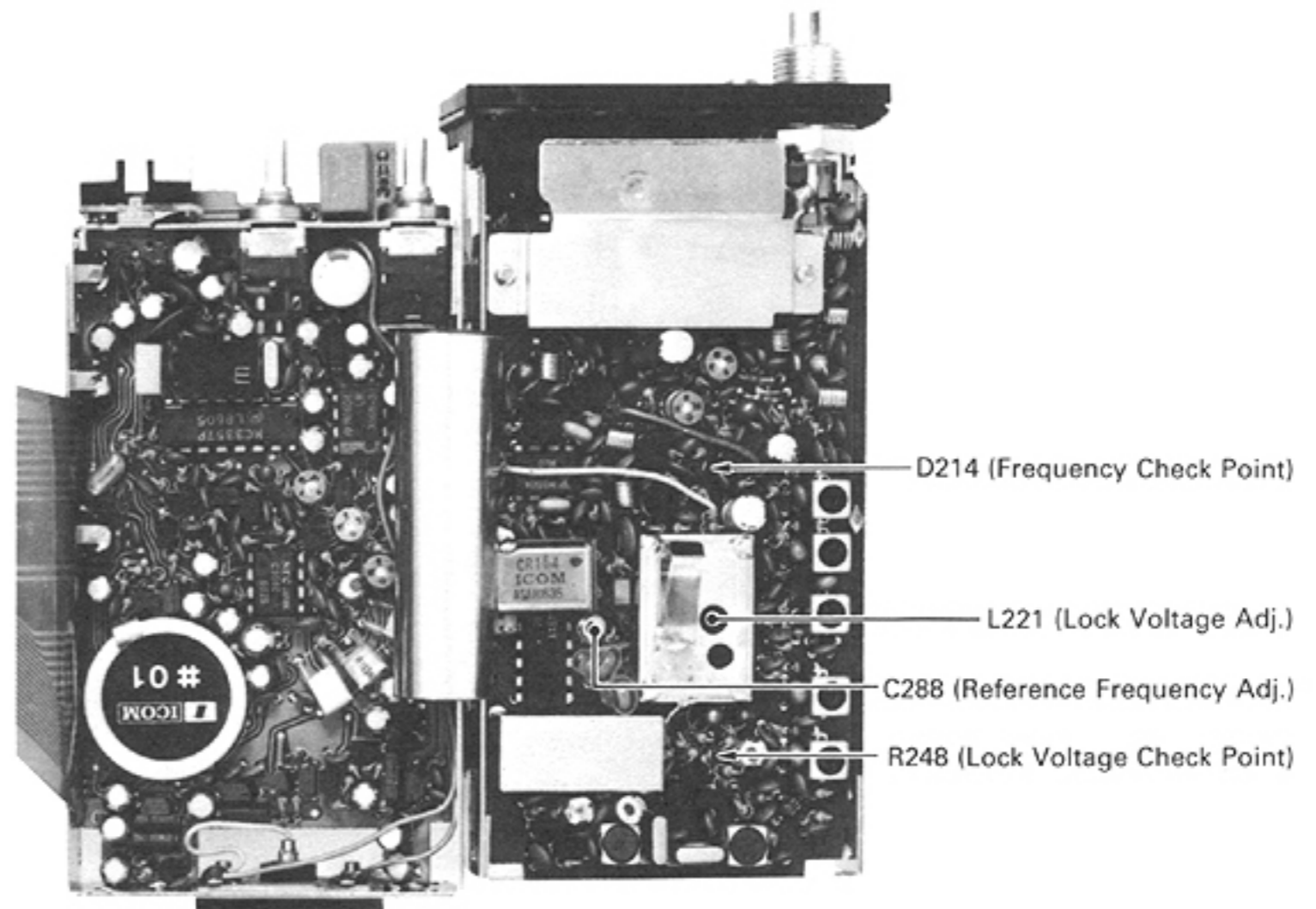

7 - 4 TRANSMITTER ADJUSTMENT

INSTRUMENTS REQUIRED		CONNECTIONS					
<p>(1) VOLTAGE REGULATED POWER SUPPLY</p> <ul style="list-style-type: none"> • OUTPUT VOLTAGE : DC 13.2V • CURRENT CAPACITY : 2A <p>(2) RF POWER METER (TERMINAND TYPE)</p> <ul style="list-style-type: none"> • MEASURING RANGE : 0~5W • FREQUENCY MINIMUM : AT LEAST 180MHz • IMPEDANCE : 50Ω • SWR : LESS THAN 1:1.2 <p>(3) AUDIO GENERATOR</p> <ul style="list-style-type: none"> • OUTPUT FREQUENCY : 50~3000Hz • OUTPUT LEVEL : 0~200mV • DISTORTION : LESS THAN 0.1% <p>(4) AMMETER</p> <ul style="list-style-type: none"> • MEASURING RANGE : 0~2A <p>(5) AC MILLIVOLTMETER</p> <ul style="list-style-type: none"> • MEASURING RANGE : 10mV~2V <p>(6) FM DEVIATION METER</p> <ul style="list-style-type: none"> • FREQUENCY MINIMUM : AT LEAST 180MHz • MEASURING RANGE : 0~±10kHz • EQUIPPED FILTERS : HPF OFF LPF 20kHz • DE-EMPHASIS : OFF <p>(7) DIRECTIONAL COUPLER</p> <ul style="list-style-type: none"> • FREQUENCY MINIMUM : AT LEAST 180MHz 							
ADJUSTMENT	ADJUSTMENT CONDITIONS	MEASUREMENT			VALUE	ADJUSTMENT POINT	
		UNIT	LOCATION	UNIT		ADJUST	
OUTPUT POWER SET	1	Top panel	Connect a power meter to ANTENNA CONNECTOR. Connect an ammeter in series between the power supply and the transceiver.	5W (at 13.2V) Less than 1.4A 3W (at 8.4V) Less than 1.25A	PLL	R272	
	2			0.5W Less than 0.55A	PLL	R275	
VERIFY OUTPUT POWER AT THE BAND EDGES	1	Top panel	Connect a power meter to ANTENNA CONNECTOR.	4.5~5.5W (at 13.2V) 2.5~3.5W (at 8.4V)		Verify	
	2			0.4~0.6W on both upper and lower band edges			
DEVIATION	1	Top panel	Connect a deviation meter to ANTENNA CONNECTOR through the attenuator.	±4.0kHz (#01, #02) ±2.0kHz (#03)	MAIN	R186	
	2			±3.0kHz~±4.0kHz (#01, #02) ±1.5kHz~±2.0kHz (#03)			Verify
	3			Less than ±4.6kHz (#01, #02) Less than ±2.3kHz (#03)	MAIN	Verify	

ADJUSTMENT	ADJUSTMENT CONDITIONS	MEASUREMENT		VALUE	ADJUSTMENT POINT	
		UNIT	LOCATION		UNIT	ADJUST
VERIFY TRANSMIT S/N RATIO	1 <ul style="list-style-type: none"> Apply AF signal 1kHz/17mV to MIC CONNECTOR. Transmit mode 	Top panel	Connect a millivoltmeter to the deviation meter.	Recording the reading		
	2 <ul style="list-style-type: none"> Apply no signal to MIC CONNECTOR. 					
CTCSS DEVIATION	1 <ul style="list-style-type: none"> Operating frequency: 161.00MHz (#01, #03) 140.00MHz (#02) Tone number: 01 Apply no signal to MIC CONNECTOR. Transmit mode 	Top panel	Connect a deviation meter to ANTENNA CONNECTOR through the attenuator.	±0.75kHz (#01, #02) ±0.3kHz (#03)	MAIN	R115
	2 <ul style="list-style-type: none"> Operating frequency: 148.00MHz and 174.00MHz (#01, #03) 136.00MHz and 144.00MHz (#02) Tone number: 01 and 37 Apply no signal to MIC CONNECTOR. 					
DTMF OPERATION AND DEVIATION	1 <ul style="list-style-type: none"> Operating frequency: 161.00MHz (#01, #03) 140.00MHz (#02) Tone number: 01 and 37 Apply no signal to MIC CONNECTOR. Push and hold PTT SWITCH then push ENT key. 		Release the [PTT] SWITCH to check the transmit holding time	Keep the transmit mode for approx. 1 second.		Verify
	2 <ul style="list-style-type: none"> Push and hold the [PTT] SWITCH then push ENT key for a while. 	Top panel	Connect a deviation meter to ANTENNA CONNECTOR through the attenuator.	±3.5kHz (#01, #02) ±1.75kHz (#03)	MAIN	R112
	3 <ul style="list-style-type: none"> Push and hold the [PTT] SWITCH then push each on the KEYBOARD. 	Front panel		To verify each key's tone sound from the speaker.		

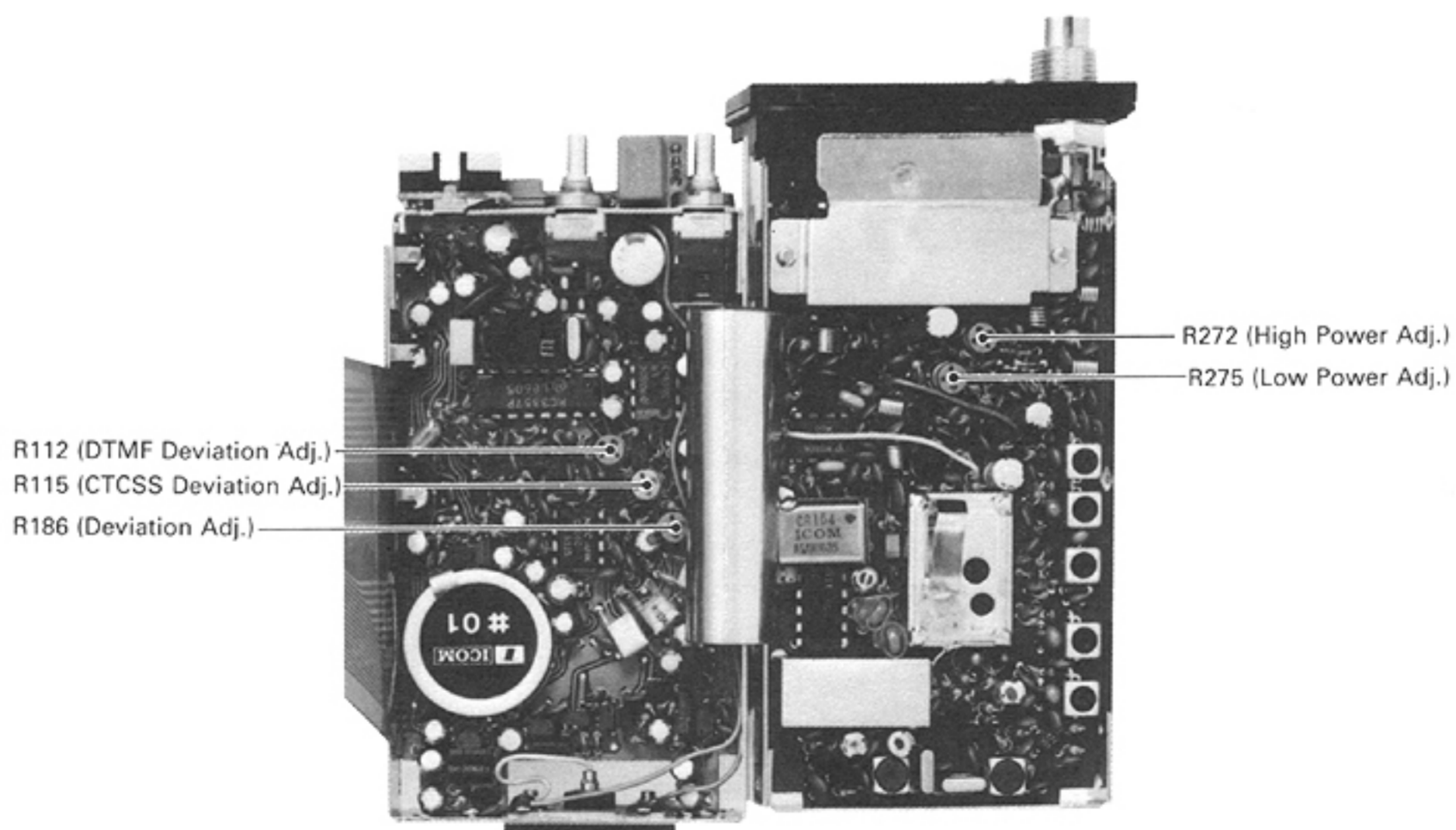

7 - 5 RECEIVER ADJUSTMENT

INSTRUMENTS REQUIRED		CONNECTIONS				
(1) VOLTAGE REGULATED POWER SUPPLY • OUTPUT VOLTAGE : DC 13.2V • CURRENT CAPACITY : 2A (2) OSCILLOSCOPE • FREQUENCY RANGE : DC~20MHz • MEASURING RANGE : 0.01~10V (3) AC MILLIVOLTMETER • MEASURING RANGE : 10mV~10V (4) SIGNAL GENERATOR • FREQUENCY RANGE : 130~180MHz • OUTPUT LEVEL : 0.1μV~32mV (5) DISTORTION METER • FREQUENCY RANGE : 1kHz±10Hz • MEASURING RANGE : 1%~100% (6) EXTERNAL SPEAKER • IMPEDANCE : 8Ω (7) AUDIO GENERATOR • OUTPUT FREQUENCY : 50~3000Hz • OUTPUT LEVEL : 0~200mV • DISTORTION : LESS THAN 0.1%						
ADJUSTMENT	ADJUSTMENT CONDITIONS	MEASUREMENT		VALUE	ADJUSTMENT POINT	
		UNIT	LOCATION		UNIT	ADJUST
SENSITIVITY	1	Top panel	Connect a distortion meter to the EXTERNAL SPEAKER JACK with an 8Ω load.	Minimum distortion level (Less than 0.4μV for 12dB SINAD)	PLL	
NOTE: Adjust coils as above for 2 or 3 times.						
VERIFY SENSITIVITY AT THE BAND EDGES	1	Top panel	Connect a distortion meter to the EXTERNAL SPEAKER JACK with an 8Ω load.	Less than 0.4μV for 12dB SINAD on both upper and lower band edges.		Verify
TONE SQUELCH SENSITIVITY	1	Top panel	Connect a speaker to the EXTERNAL SPEAKER JACK.	No sound from the speaker		Verify
	2			Receive signal sound from the speaker "CALL" INDICATOR lights up.		Verify

ADJUSTMENT	ADJUSTMENT CONDITIONS	MEASUREMENT		VALUE	ADJUSTMENT POINT	
		UNIT	LOCATION		UNIT	ADJUST
AF OUTPUT	1 <ul style="list-style-type: none"> Apply RF signal to ANTENNA CONNECTOR. Level: $32\mu\text{V}$ (-77dBm) Dev.: $\pm 3.5\text{kHz}$ (#01, #02) $\pm 1.75\text{kHz}$ (#03) Mod.: 1kHz MONITOR SWITCH: ON 	Top panel	Connect an AC millivoltmeter to the EXTERNAL SPEAKER JACK with an $8\ \Omega$ load.	Greater than 2V at 10% distortion		Verify
TIGHT SQUELCH SENSITIVITY	1 <ul style="list-style-type: none"> SQUELCH CONTROL: MAX. C.W. Apply RF signal to ANTENNA CONNECTOR. Level: Approx. $1\mu\text{V}$ (-107dBm) Dev.: $\pm 3.5\text{kHz}$ (#01, #02) $\pm 1.75\text{kHz}$ (#03) Mod.: 1kHz 	Top panel	Connect a speaker to the EXTERNAL SPEAKER JACK.	Squelch opens		Verify

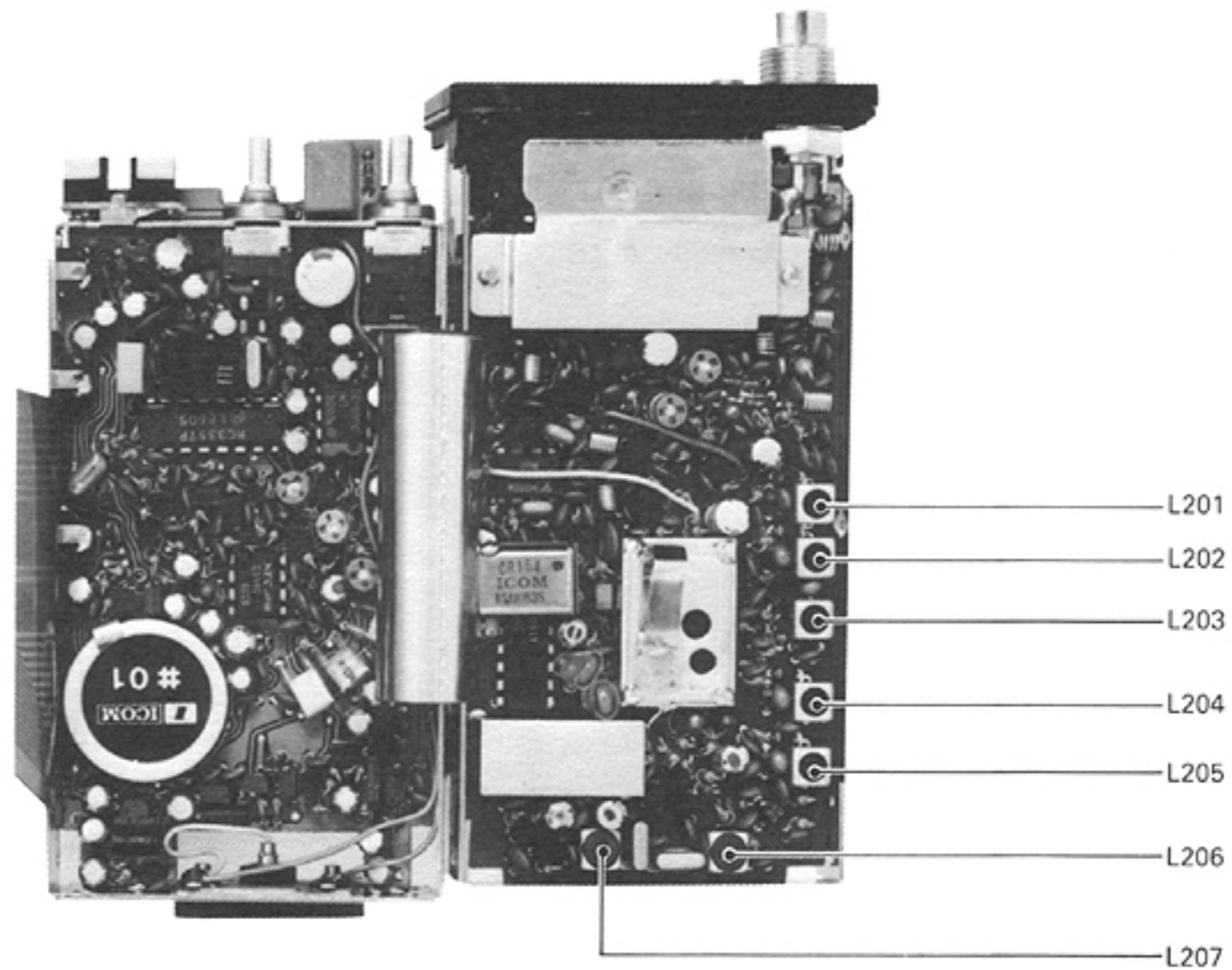

SECTION 8 VOLTAGE DIAGRAMS

8 - 1 MAIN UNIT VOLTAGE DIAGRAM

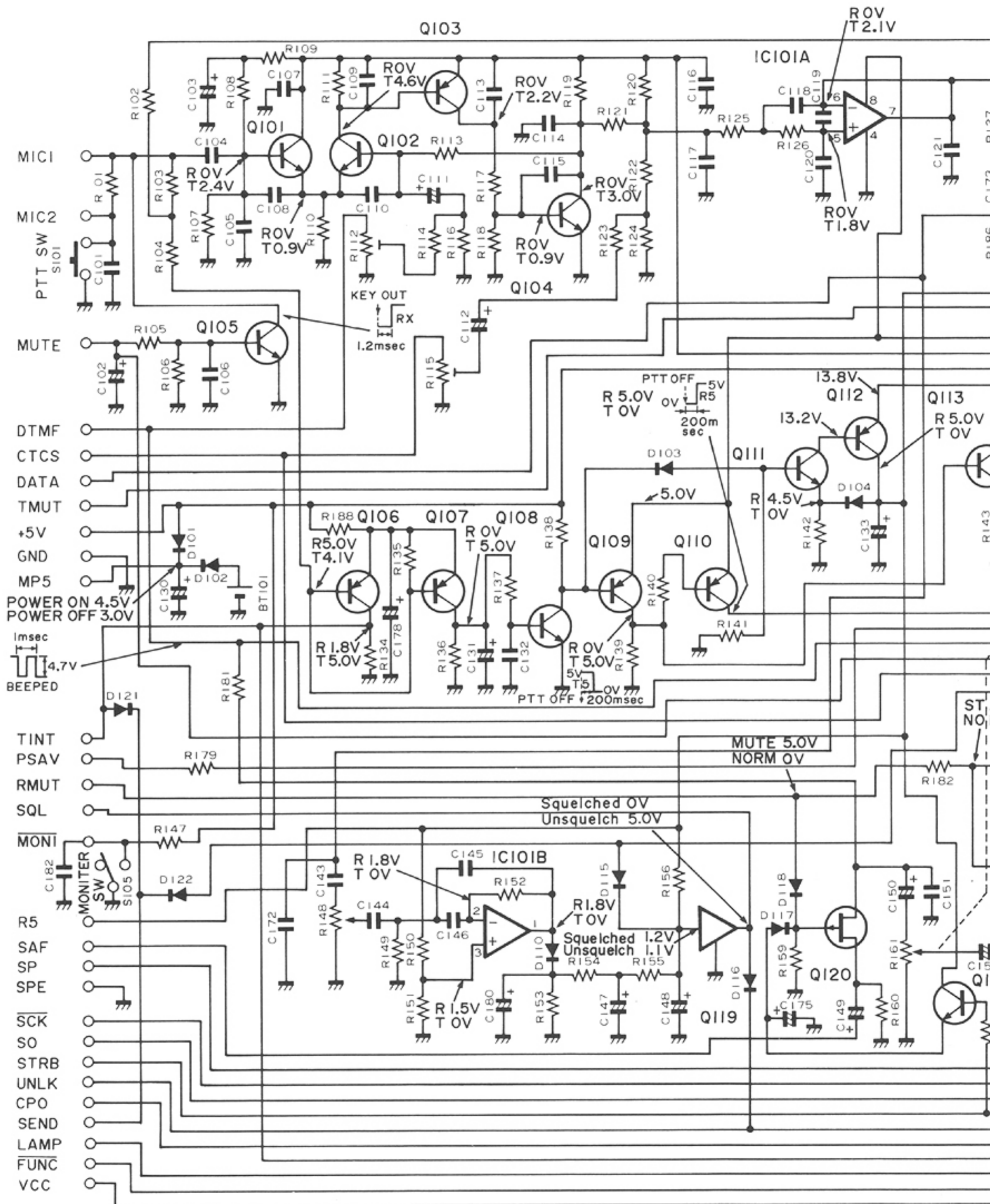

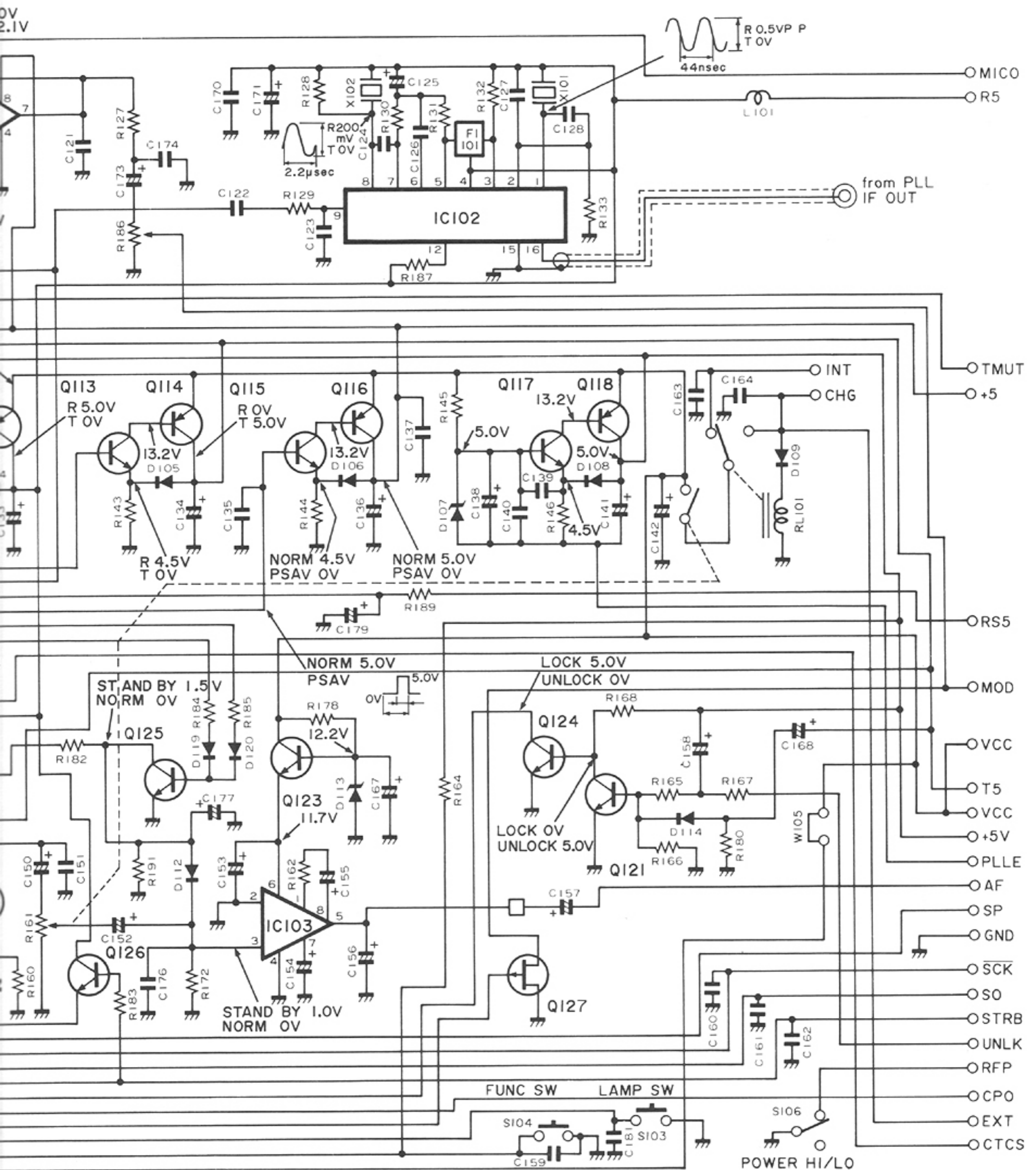

8 - 2 PLL UNIT

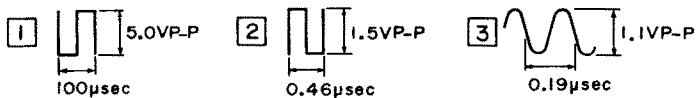
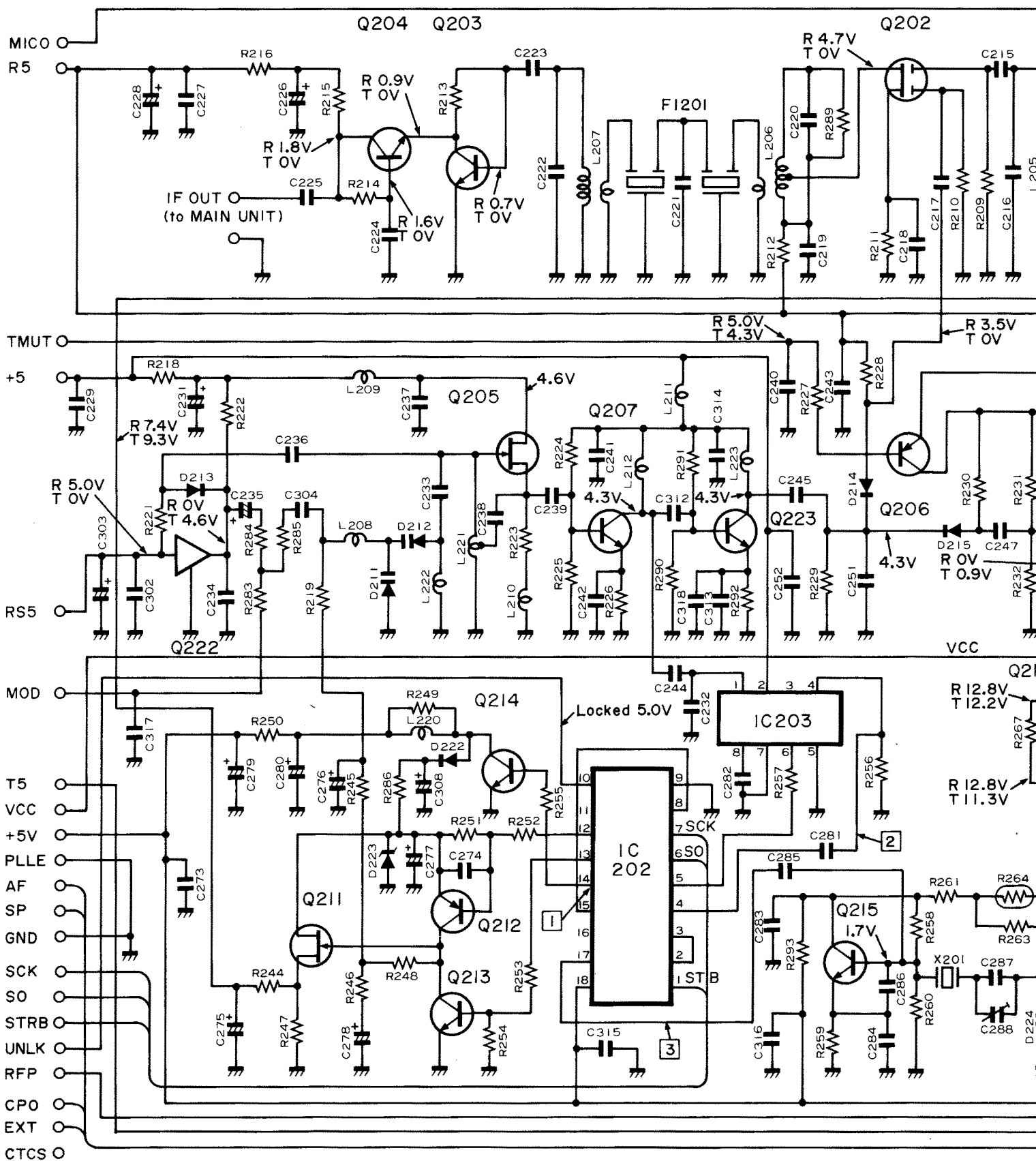

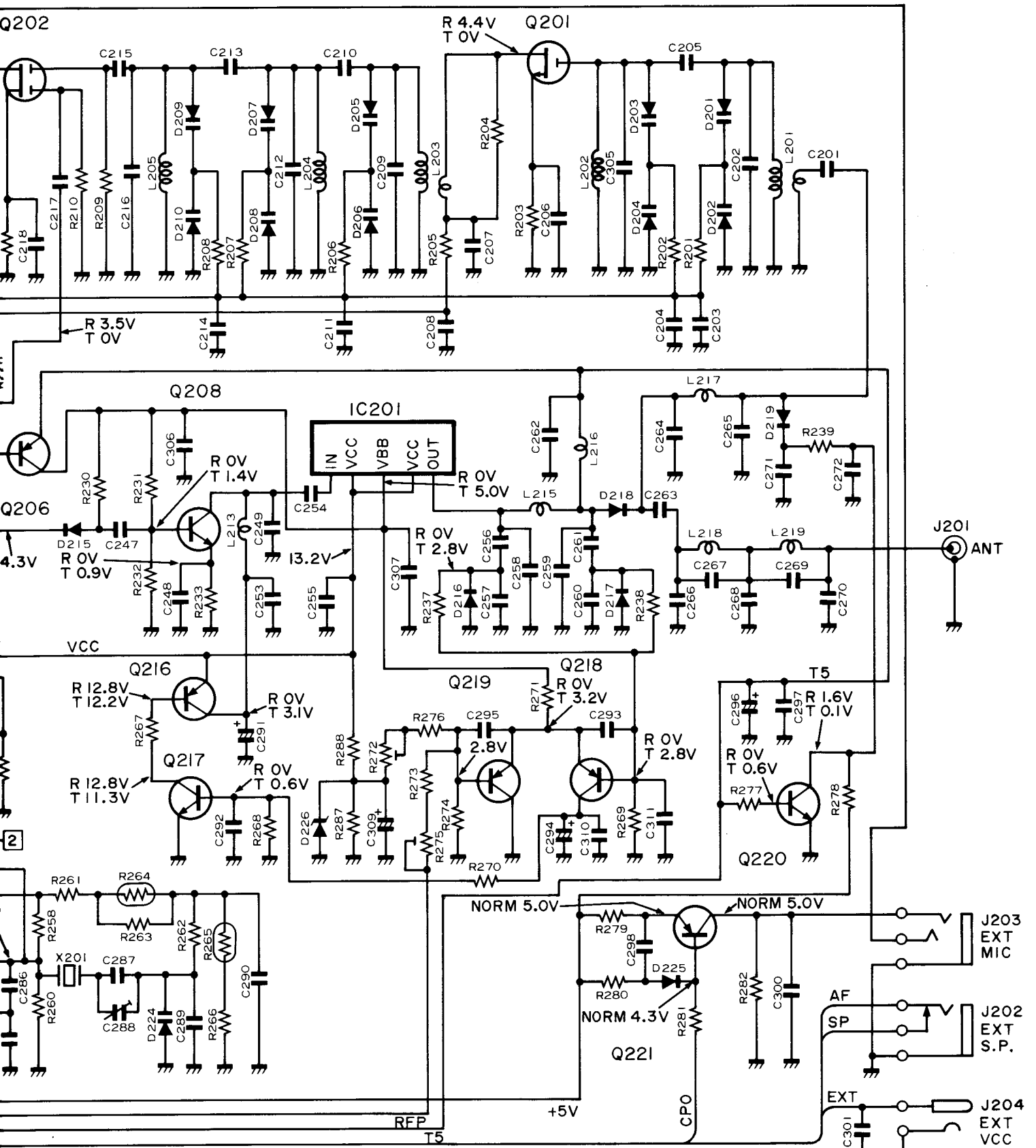

• VCC=13.2V
• Frequency=160.00MHz
• Power=5W(Hi Power)

8 - 3 LOGIC UNIT VOLTAGE DIAGRAM

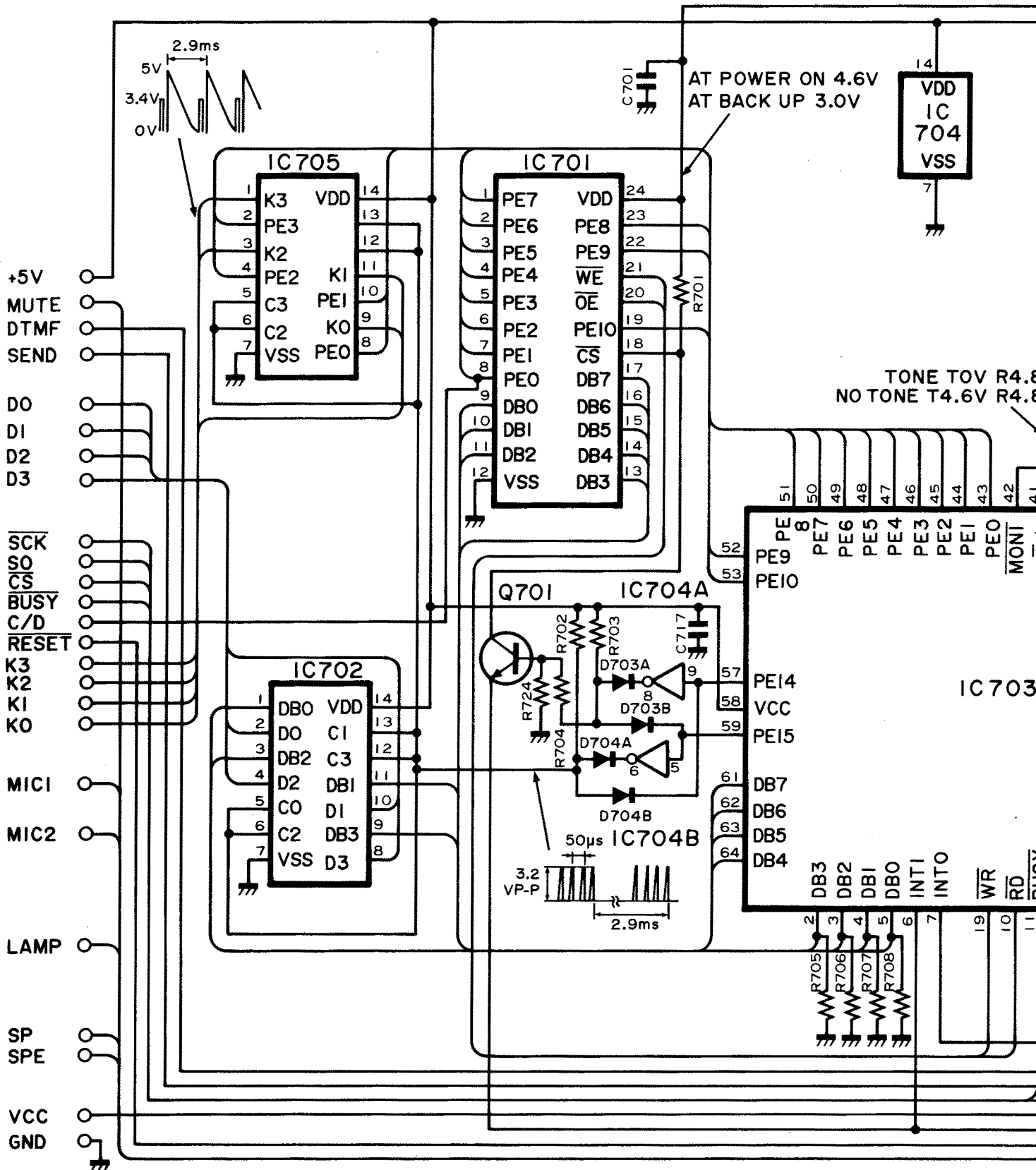

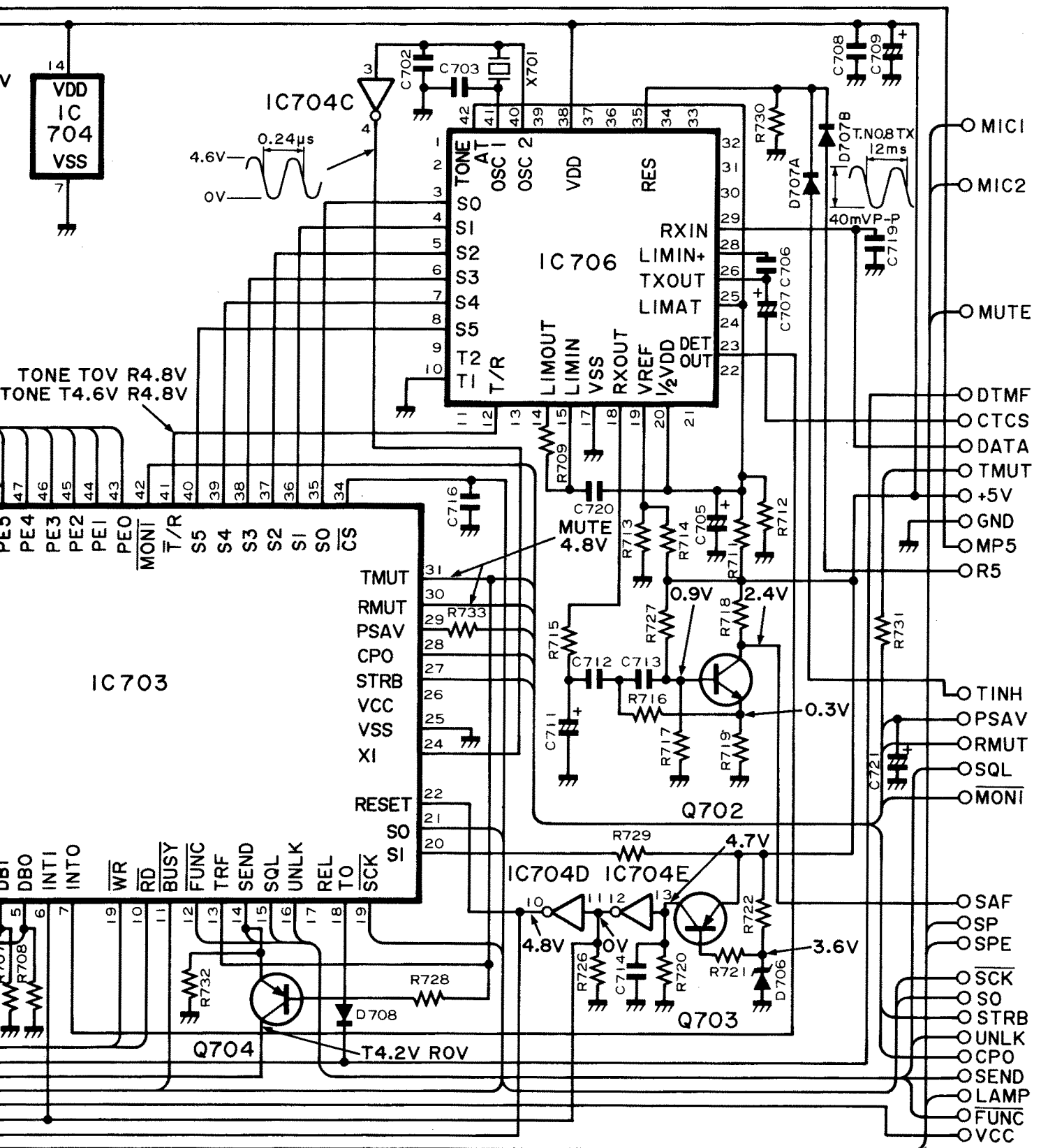

8 - 4 DISPLAY UNIT VOLTAGE DIAGRAM

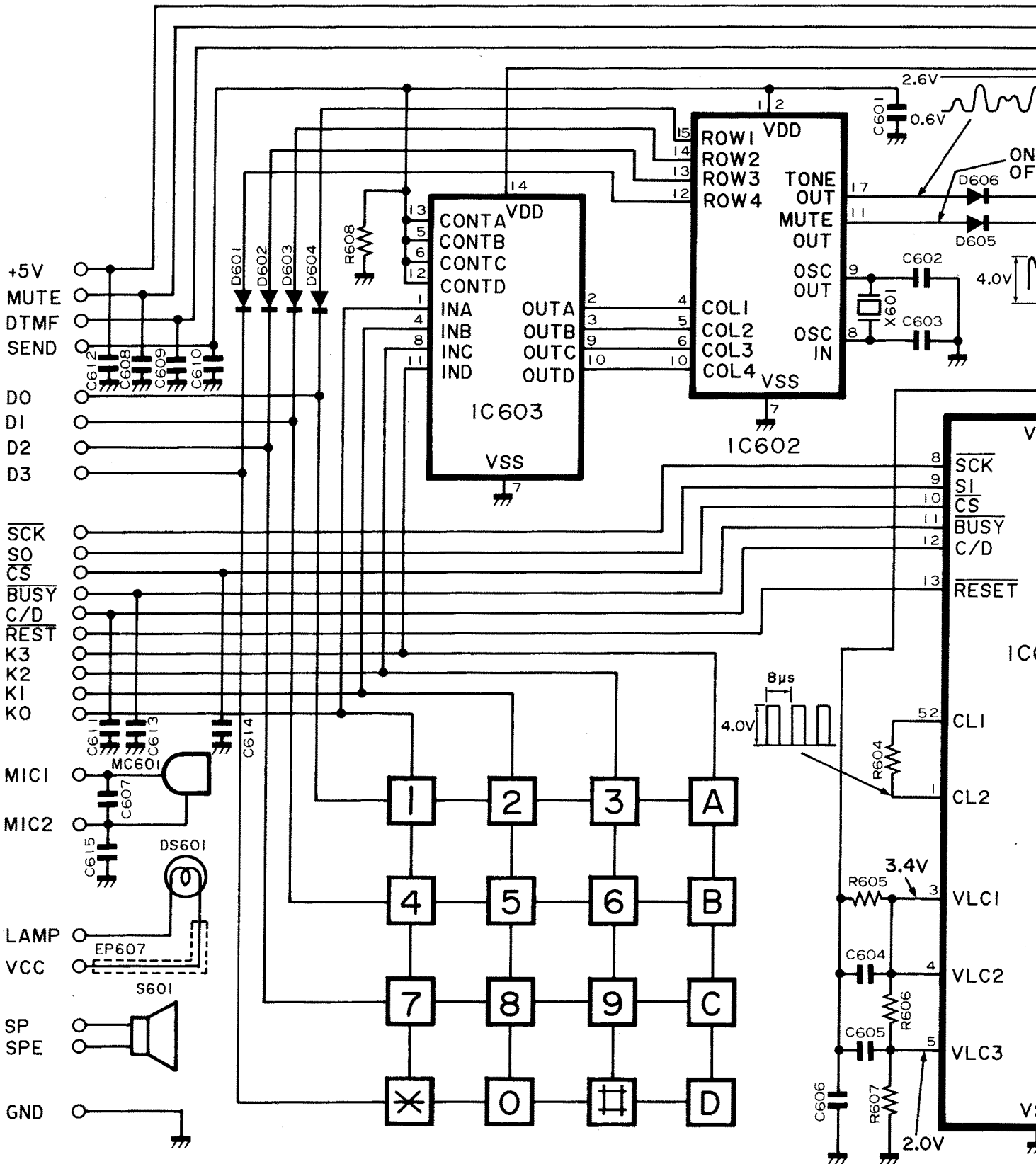

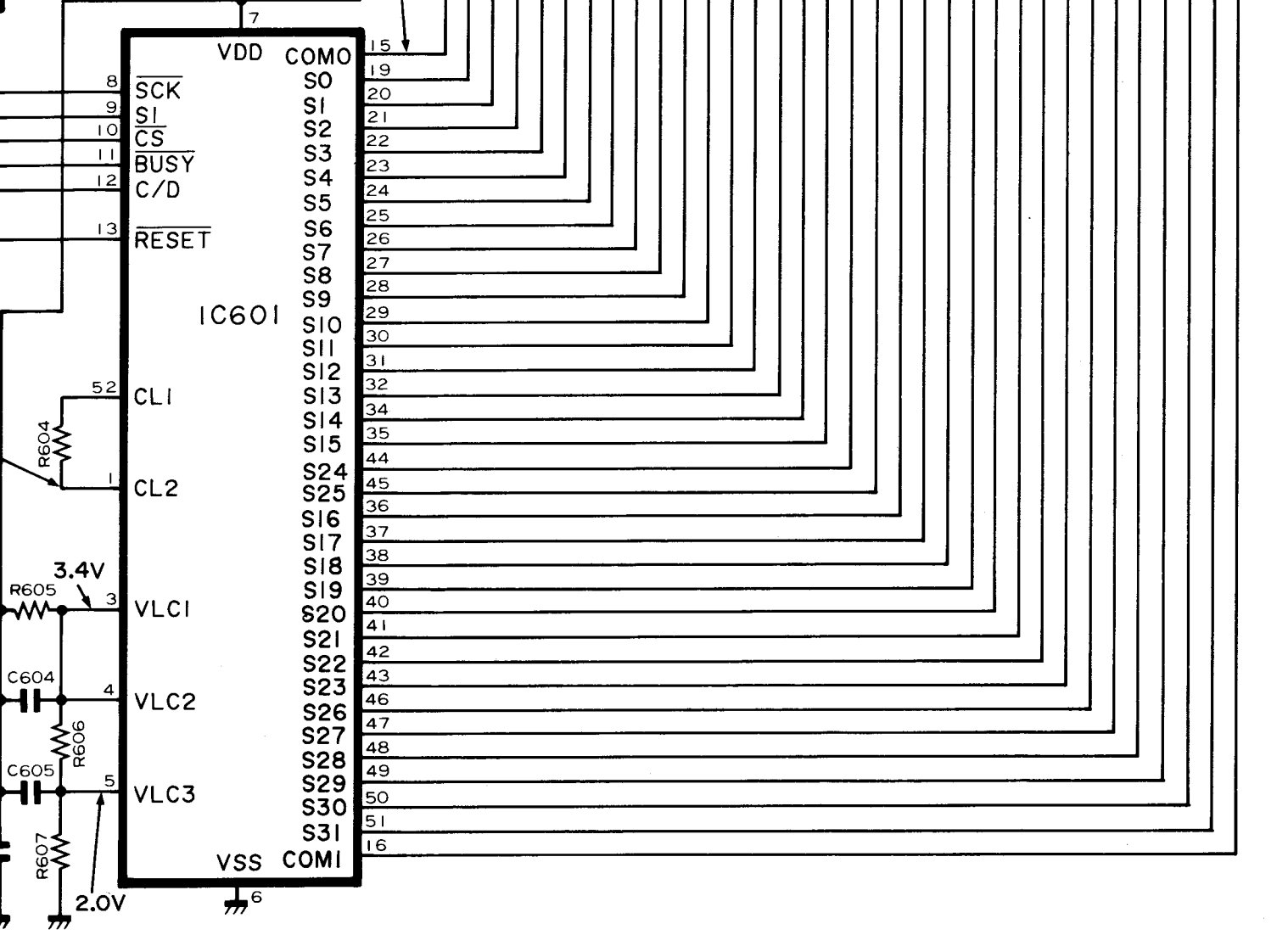
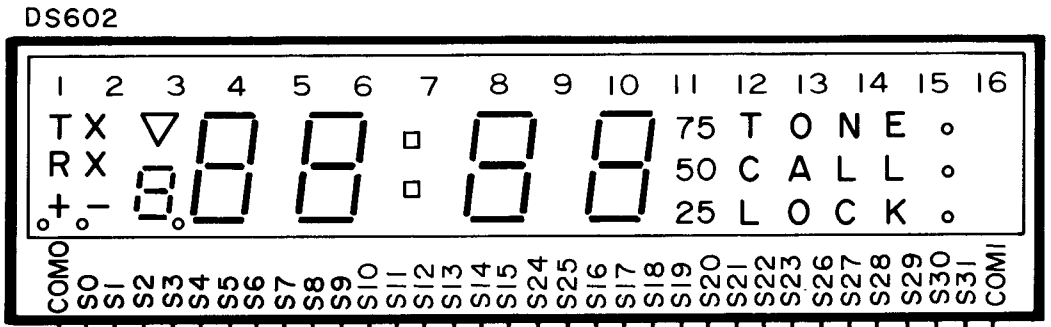
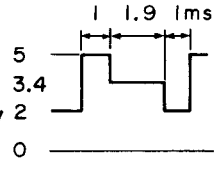
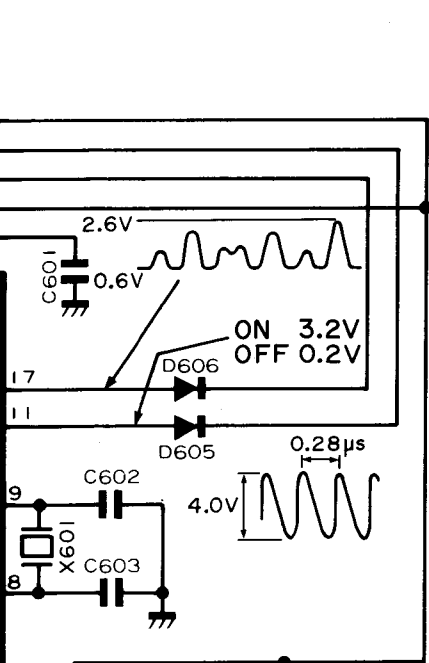

SECTION 9 BOARD LAYOUTS

9 - 1 MAIN UNIT

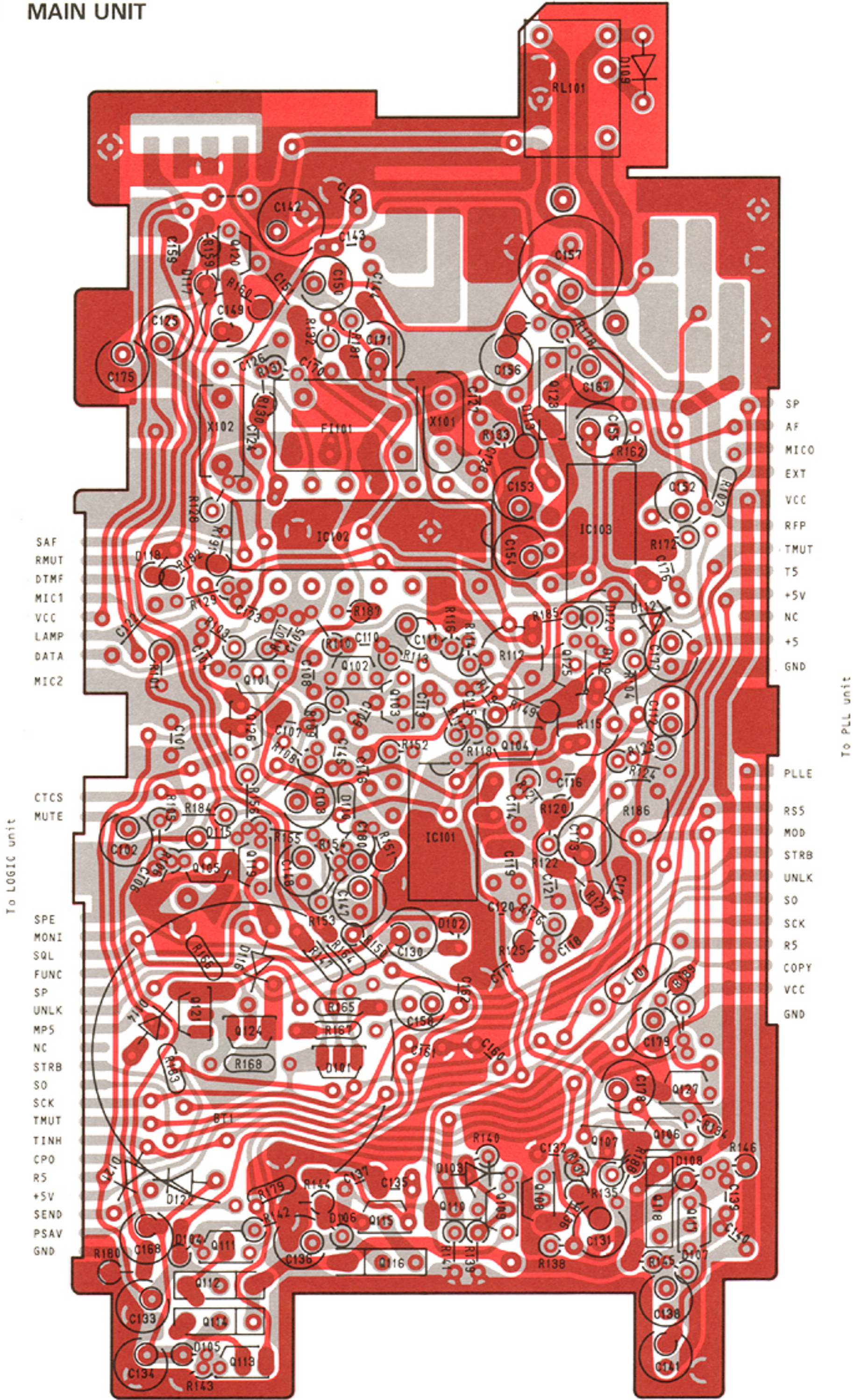

9 - 2 PLL UNIT

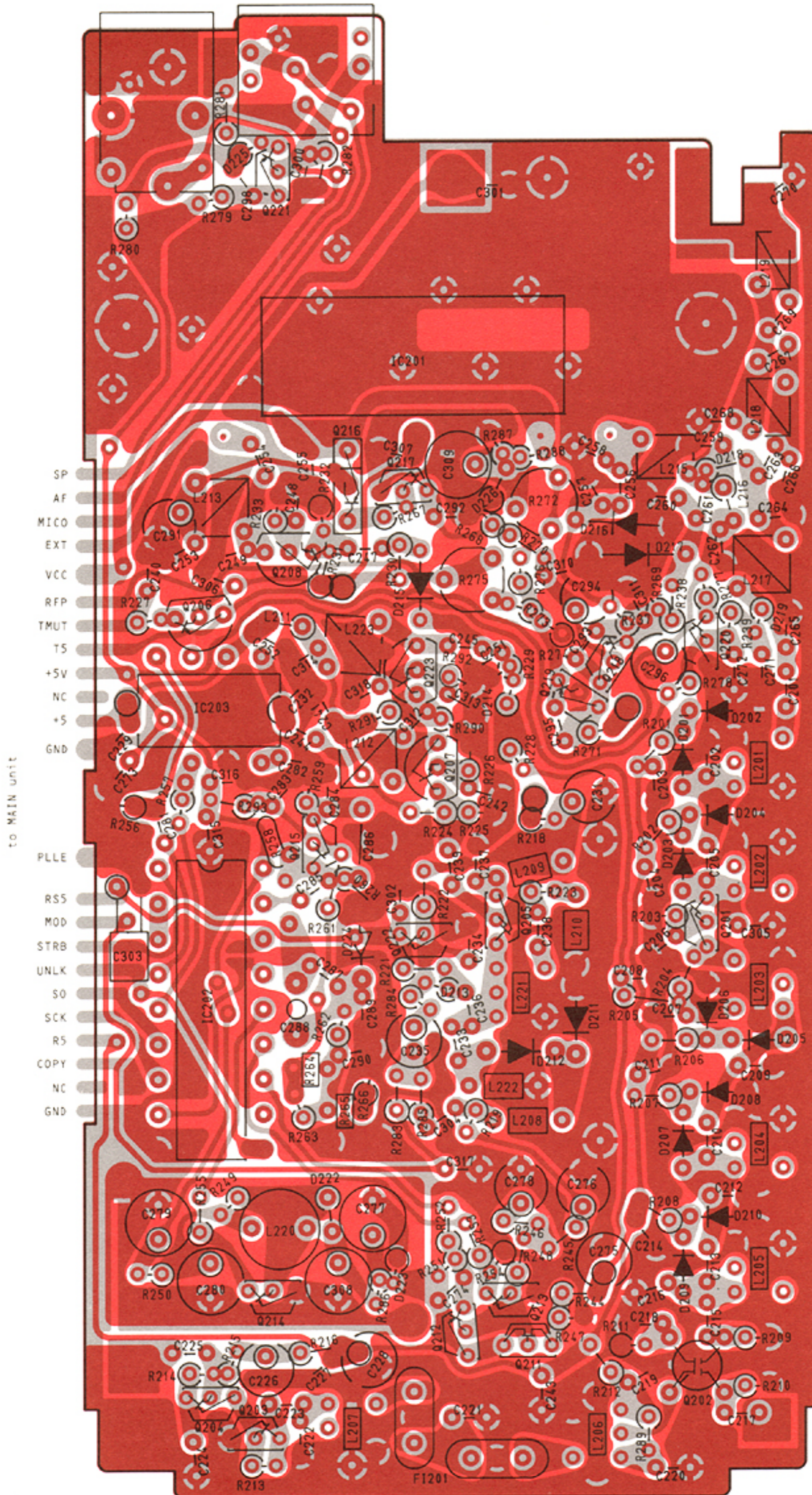

LOGIC UNIT

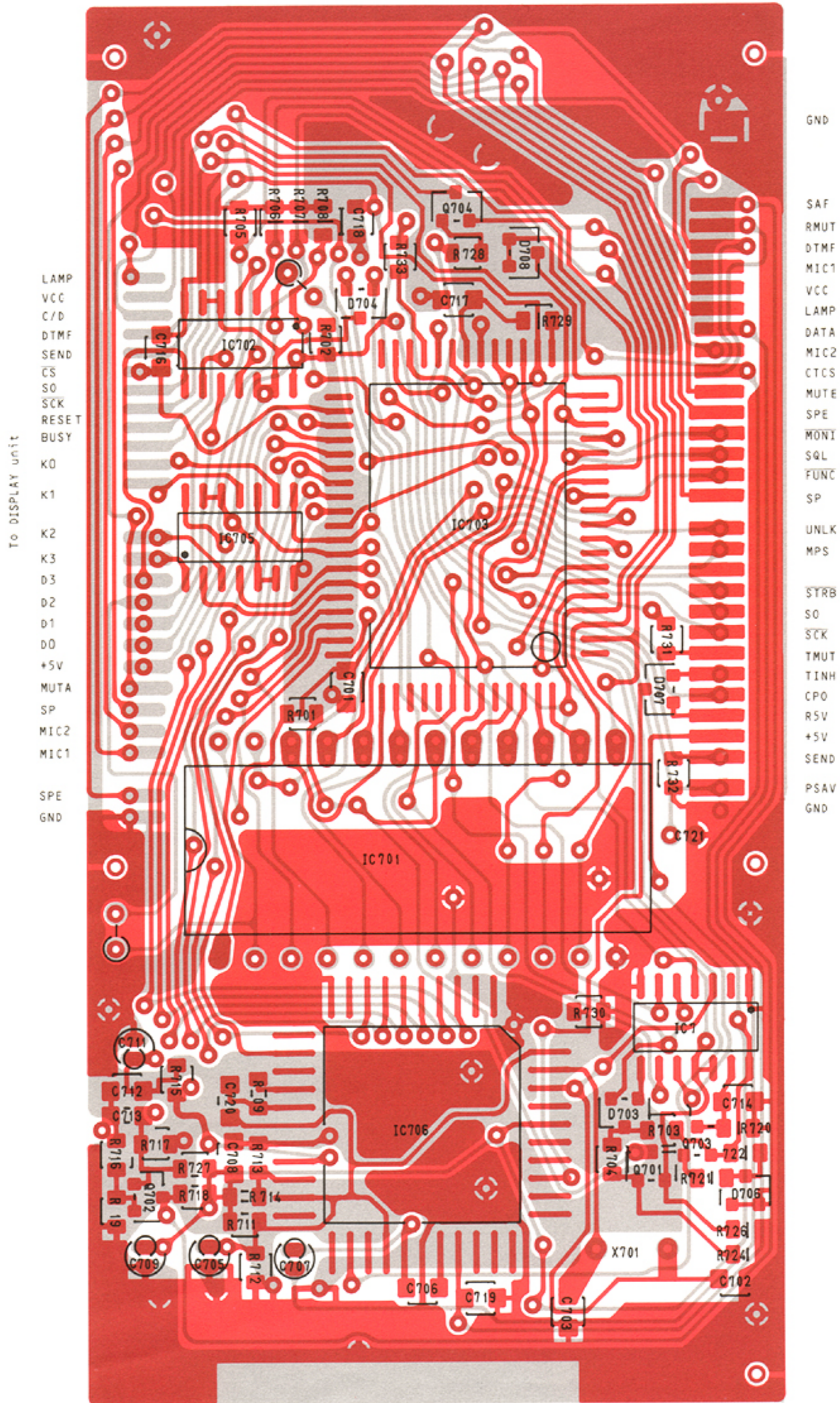

9 - 4 DISPLAY UNIT

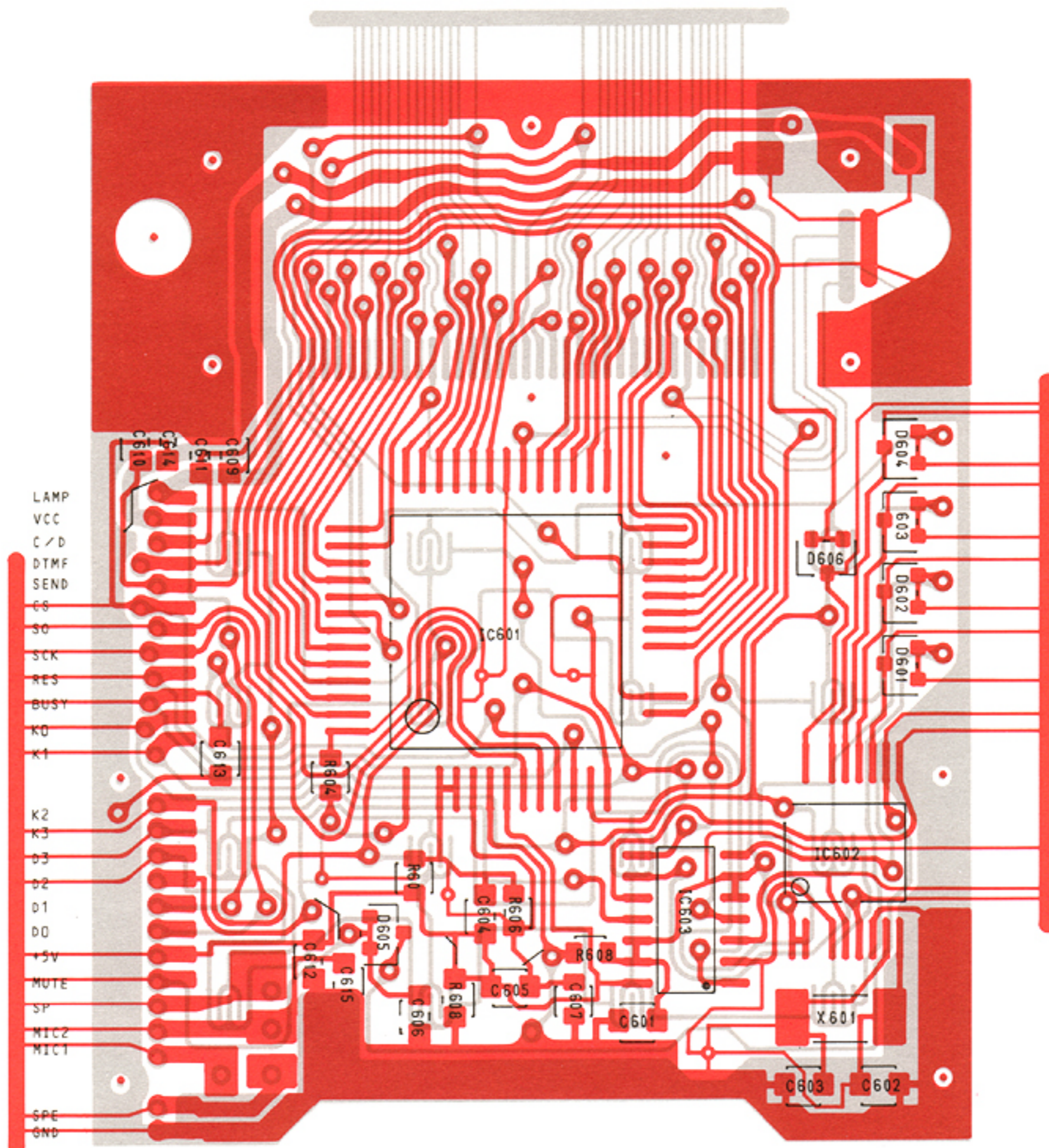

SECTION 10 PARTS LIST

MAIN UNIT			MAIN UNIT			
REF. NO.	DESCRIPTION	TYPE (PART NO.)	REF. NO.	DESCRIPTION	TYPE (PART NO.)	
IC101	IC	μ PC358C	L101	CHOKE	LAL03NA 100K	
IC102	IC	MC3357P	R101	RESISTOR	33K	ELR10
IC103	IC	LM386N-3	R102	RESISTOR	1K	R10
Q101	TRANSISTOR	2SC2458 GR	R103	RESISTOR	1K	ELR10
Q102	TRANSISTOR	2SC2458 GR	R104	RESISTOR	1.2K	ELR10
Q103	TRANSISTOR	2SA1048 GR	R105	RESISTOR	150K	ELR10
Q104	TRANSISTOR	2SC2458 GR	R106	RESISTOR	100K	ELR10
Q105	TRANSISTOR	2SC2458 GR	R107	RESISTOR	120K	ELR10
Q106	TRANSISTOR	2SA1048 GR	R108	RESISTOR	120K	ELR10
Q107	TRANSISTOR	2SA1048 GR	R109	RESISTOR	470	ELR10
Q108	TRANSISTOR	2SC2458 GR	R110	RESISTOR	12K	ELR10
Q109	TRANSISTOR	2SA1048 GR	R111	RESISTOR	5.6K	ELR10
Q110	TRANSISTOR	2SA1048 GR	R112	TRIMMER	33K	RHM0AN405A
Q111	TRANSISTOR	2SC2458 GR	R113	RESISTOR	330K	ELR10
Q112	TRANSISTOR	2SB909M R	R114	RESISTOR	22K	ELR10
Q113	TRANSISTOR	2SC2458 GR	R115	TRIMMER	100K	RHM0A1505A
Q114	TRANSISTOR	2SB909M R	R116	RESISTOR	470	ELR10
Q115	TRANSISTOR	2SC2458 GR	R117	RESISTOR	2.2K	ELR10
Q116	TRANSISTOR	2SB909M R	R118	RESISTOR	1K	ELR10
Q117	TRANSISTOR	2SC2458 GR	R119	RESISTOR	3.3K	ELR10
Q118	TRANSISTOR	2SB909M R	R120	RESISTOR	150K	ELR10
Q119	TRANSISTOR	2SC3399 K	R121	RESISTOR	220K	ELR10
Q120	TRANSISTOR	2SJ105 Y	R122	RESISTOR	39K	ELR10
Q121	TRANSISTOR	2SC2458 GR	R123	RESISTOR	10K	ELR10
Q123	TRANSISTOR	2SD1225M R	R124	RESISTOR	33K	ELR10
Q124	TRANSISTOR	2SC2458 GR	R125	RESISTOR	33K	ELR10
Q125	TRANSISTOR	2SC2458 GR	R126	RESISTOR	39K	ELR10
Q126	TRANSISTOR	2SC2458 GR	R127	RESISTOR	12K	ELR10
Q127	FET	2SJ105 Y	R128	RESISTOR	1.5K	ELR10
D101	DIODE	1SS233	R129	RESISTOR	470	ELR10
D102	DIODE	1SS211	R130	RESISTOR	47K	ELR10
D103	DIODE	1SS211	R131	RESISTOR	1.5K	ELR10 (#01, #02)
D104	DIODE	1SS211		RESISTOR	2.2K	ELR10 (#03)
D105	DIODE	1SS211	R132	RESISTOR	1.5K	ELR10 (#01, #02)
D106	DIODE	1SS211		RESISTOR	2.2K	ELR10 (#03)
D107	ZENER	RD5.1JS B2	R133	RESISTOR	22K	ELR10
D108	DIODE	1SS211	R134	RESISTOR	47K	ELR10
D109	DIODE	1SS211	R135	RESISTOR	10K	ELR10
D110	DIODE	1SS211	R136	RESISTOR	100K	ELR10
D112	DIODE	1SS211	R137	RESISTOR	220K	ELR10
D113	ZENER	RD12JS B2	R138	RESISTOR	33K	ELR10
D114	DIODE	1SS211	R139	RESISTOR	10K	ELR10
D115	DIODE	1SS211	R140	RESISTOR	180K	ELR10
D116	DIODE	1SS211	R141	RESISTOR	10K	ELR10
D117	DIODE	1SS211	R142	RESISTOR	10K	ELR10
D118	DIODE	1SS211	R143	RESISTOR	10K	ELR10
D119	DIODE	1SS211	R144	RESISTOR	10K	ELR10
D120	DIODE	1SS211	R145	RESISTOR	6.8K	ELR10
D121	DIODE	1SS211	R146	RESISTOR	10K	ELR10
D122	DIODE	1SS211	R147	RESISTOR	100K	R10
FI101	CERAMIC FILTER	CFW455 E (#01, #02)	R148	VARIABLE	RK9A1000NA	10KB
	CERAMIC FILTER	CFW455 HT (#03)	R149	RESISTOR	5.6K	ELR10
X101	CRYSTAL	CR-70	R150	RESISTOR	330K	ELR10
X102	DISCRIMINATOR	CDB455 C7A	R151	RESISTOR	180K	ELR10
			R152	RESISTOR	1M	ELR10
			R153	RESISTOR	100K	ELR10
			R154	RESISTOR	1K	ELR10
			R155	RESISTOR	150K	ELR10

MAIN UNIT

REF. NO.	DESCRIPTION	TYPE (PART NO.)	
R156	RESISTOR	680K	ELR10
R159	RESISTOR	470K	ELR10
R160	RESISTOR	1M	ELR10
R161	VARIABLE	RK9A11003A	10KA
R162	RESISTOR	1.8K	ELR10 (#01, #02)
	RESISTOR	2.2K	ELR10 (#03)
R164	RESISTOR	100K	R10
R165	RESISTOR	33K	R10
R166	RESISTOR	39K	R10
R167	RESISTOR	120K	R10
R168	RESISTOR	470K	R10
R172	RESISTOR	150K	ELR10
R178	RESISTOR	220	ELR10
R179	RESISTOR	1K	R10
R180	RESISTOR	220K	ELR10
R181	RESISTOR	27K	ELR10 (#01, #02)
	RESISTOR	68K	ELR10 (#03)
R182	RESISTOR	220K	ELR10
R183	RESISTOR	47K	R10
R184	RESISTOR	100K	ELR10
R185	RESISTOR	33K	ELR10
R186	TRIMMER	RHM0A1505A	100K
R187	RESISTOR	100K	ELR10
R188	RESISTOR	470	ELR10
R189	RESISTOR	10	ELR10
R191	RESISTOR	150K	ELR10
C101	CERAMIC	0.001	50V
C102	ELECTROLYTIC	10	16V RC3
C103	ELECTROLYTIC	10	16V RC3
C104	BARRIER LAY	0.01	25V
C105	CERAMIC	470P	50V
C106	CERAMIC	470P	50V
C107	CERAMIC	470P	50V
C108	CERAMIC	470P	50V
C109	CERAMIC	470P	50V
C110	CERAMIC	470P	50V
C111	TANTALUM	DN1V0R1	
C112	ELECTROLYTIC	0.22	50V RC3
C113	CERAMIC	470P	50V
C114	CERAMIC	470P	50V
C115	CERAMIC	0.001	50V
C116	CERAMIC	0.001	50V
C117	MYLAR	0.0022	50V
C118	MYLAR	0.01	50V
C119	CERAMIC	470P	50V
C120	CERAMIC	120P	50V
C121	CERAMIC	470P	50V
C122	MYLAR	0.056	50V
C123	CERAMIC	0.001	50V
C124	CERAMIC	82P	50V
C125	ELECTROLYTIC	0.1	50V RC3
C126	BARRIER LAY	0.1	16V
C127	CERAMIC	68P	50V
C128	CERAMIC	120P	50V
C130	ELECTROLYTIC	47	6.3V RC3
C131	ELECTROLYTIC	2.2	50V RC3
C132	CERAMIC	0.001	50V
C133	ELECTROLYTIC	22	6.3V RC3
C134	ELECTROLYTIC	22	6.3V RC3
C135	CERAMIC	470P	50V
C136	ELECTROLYTIC	22	6.3V RC3
C137	CERAMIC	0.001	50V
C138	ELECTROL	22	6.3V RC3

MAIN UNIT

REF. NO.	DESCRIPTION	TYPE (PART NO.)	
C139	CERAMIC	470P	50V
C140	CERAMIC	0.001	50V
C141	ELECTROLYTIC	22	6.3V RC3
C142	ELECTROLYTIC	47	25V MS7
C143	CERAMIC	0.001	50V
C144	CERAMIC	0.001	50V
C145	CERAMIC	10P	50V
C146	CERAMIC	0.001	50V
C147	ELECTROLYTIC	0.22	50V RC3
C148	ELECTROLYTIC	0.22	50V RC3
C149	ELECTROLYTIC	1	50V RC3
C150	ELECTROLYTIC	1	50V RC3
C151	BARRIER LAY	0.018	25V
C152	ELECTROLYTIC	0.1	50V MS5
C153	ELECTROLYTIC	10	16V MS5
C154	ELECTROLYTIC	10	16V MS5
C155	ELECTROLYTIC	10	16V RC3
C156	ELECTROLYTIC	2.2	50V RC3
C157	ELECTROLYTIC	220	10V
C158	ELECTROLYTIC	4.7	25V RC3
C159	CERAMIC	470P	50V
C160	CERAMIC	47P	50V
C161	CERAMIC	47P	50V
C162	CERAMIC	47P	50V
C163	CERAMIC	0.001	50V
C164	CERAMIC	0.001	50V
C167	ELECTROLYTIC	4.7	25V RC3
C168	ELECTROLYTIC	1	50V RC3
C170	BARRIER LAY	0.01	25V
C171	ELECTROLYTIC	10	16V RC3
C172	CERAMIC	47P	50V
C173	ELECTROLYTIC	1	50V RC3
C174	MYLAR	0.0022	50V
C175	ELECTROLYTIC	0.1	50V RC3
C176	CERAMIC	470P	50V
C177	ELECTROLYTIC	2.2	50V RC3
C178	ELECTROLYTIC	10	16V RC3
C179	ELECTROLYTIC	2.2	50V RC3
C180	TANTALUM	DN1V	R47M
RL101	RELAY	OUC-SS-114D	
S101	SWITCH	SKHHAB062A	
S103	SWITCH	SKHHAB062A	
S104	SWITCH	SKHHAB062A	
S105	SWITCH	SPPH22014A	
S106	SWITCH	SPPH22014A	
BT101	LITHIUM CELL	BR2325-1HC	
EP101	P.C.B.	B-1038D	
EP102	P.C.B.	B-908	
EP103	F.C.B.	B-1045	
EP104	BEADS CORE	DL2-OP2.6-3-1.2H	
EP106	FILTER SEAT	41590	
EP107	INSULATING SEAT(J)		

PLL UNIT

REF. NO.	DESCRIPTION	TYPE (PART NO.)
IC201	IC	SC-1046 (#01, #03)
	IC	SC-1050 (#02)
IC202	IC	μPD2834C
IC203	IC	MB504
Q201	FET	2SK241 GR
Q202	FET	3SK74 M
Q203	TRANSISTOR	2SC2668 O
Q204	TRANSISTOR	2SC2668 O
Q205	FET	2SK192A Y
Q206	TRANSISTOR	2SB561 C
Q207	TRANSISTOR	2SC2026
Q208	TRANSISTOR	2SC2026
Q211	FET	2SK184 Y
Q212	TRANSISTOR	2SA1048 GR
Q213	TRANSISTOR	2SC2458 GR
Q214	TRANSISTOR	2SC3327 B
Q215	TRANSISTOR	2SC2458 GR
Q216	TRANSISTOR	2SB909 M
Q217	TRANSISTOR	2SC2458 GR
Q218	TRANSISTOR	2SA1048 GR
Q219	TRANSISTOR	2SA1048 GR
Q220	TRANSISTOR	2SC2458 GR
Q221	TRANSISTOR	2SA1048 GR
Q222	TRANSISTOR	2SC3399
Q223	TRANSISTOR	2SC2026
D201	VARICAP	1SV153
D202	VARICAP	1SV153
D203	VARICAP	1SV153
D204	VARICAP	1SV153
D205	VARICAP	1SV153
D206	VARICAP	1SV153
D207	VARICAP	1SV153
D208	VARICAP	1SV153
D209	VARICAP	1SV153
D210	VARICAP	1SV153
D211	VARICAP	1SV50E
D212	VARICAP	1SV50E
D213	DIODE	1SS216
D214	DIODE	1SS216
D215	DIODE	1SS216
D216	DIODE	1SS97
D217	DIODE	1SS97
D218	DIODE	1SS216
D219	DIODE	1SS216
D222	DIODE	1SS130
D223	ZENER	RD18J B2
D224	VARICAP	1SV50E
D225	DIODE	1SS211
D226	ZENER	RD5.1JS B2
FI201	MC	21M15B3 (#01, #02)
	MC	21M7B2 (#03)
X201	CRYSTAL	CR-164 (#01, #02)
	CRYSTAL	CR-85 (#03)
L201	COIL	LS-295
L202	COIL	LS-295
L203	COIL	LS-296
L204	COIL	LS-295
L205	COIL	LS-295
L206	COIL	LS-264

PLL UNIT

REF. NO.	DESCRIPTION	TYPE (PART NO.)
L207	COIL	LS-264
L208	CHOKE	LAL02TA 4R7
L209	CHOKE	LAL02TA 4R7
L210	CHOKE	LAL02TA 4R7
L211	CHOKE	LAL03NA 221
L212	COIL	LA-237
L213	COIL	LA-237
L215	COIL	LA-235
L216	CHOKE	LAL03A 4R7
L217	CHOKE	LA-237
L218	CHOKE	LA-235
L219	CHOKE	LA-234
L220	CHOKE	LW-30
L221	COIL	LB-188
L222	CHOKE	LAL02TA 4R7
L223	COIL	LA-237
R201	RESISTOR	150K ELR10
R202	RESISTOR	150K ELR10
R203	RESISTOR	18 ELR10
R204	RESISTOR	6.8K ELR10
R205	RESISTOR	100 ELR10
R206	RESISTOR	150K ELR10
R207	RESISTOR	150K ELR10
R208	RESISTOR	150K ELR10
R209	RESISTOR	220K ELR10
R210	RESISTOR	47K ELR10
R211	RESISTOR	18 ELR10
R212	RESISTOR	68 ELR10
R213	RESISTOR	22K ELR10
R214	RESISTOR	22K ELR10
R215	RESISTOR	3.3K ELR10
R216	RESISTOR	100 ELR10
R218	RESISTOR	100 ELR10
R219	RESISTOR	2.2K ELR10
R221	RESISTOR	8.2K ELR10
R222	RESISTOR	22K ELR10
R223	RESISTOR	100 ELR10
R224	RESISTOR	5.6K ELR10
R225	RESISTOR	4.7K ELR10
R226	RESISTOR	470 ELR10
R227	RESISTOR	6.8K ELR10
R228	RESISTOR	10K ELR10
R229	RESISTOR	22K ELR10
R230	RESISTOR	10K ELR10
R231	RESISTOR	1.2K ELR10
R232	RESISTOR	560 ELR10
R233	RESISTOR	47 ELR10
R237	RESISTOR	4.7K ELR10
R238	RESISTOR	4.7K ELR10
R239	RESISTOR	330 ELR10
R244	RESISTOR	10K ELR10
R245	RESISTOR	22K ELR10
R246	RESISTOR	2.7K ELR10
R247	RESISTOR	120K R10
R248	RESISTOR	1K R10
R249	RESISTOR	10K ELR10
R250	RESISTOR	330 ELR10
R251	RESISTOR	10K ELR10
R252	RESISTOR	100K ELR10
R253	RESISTOR	100K ELR10
R254	RESISTOR	33K ELR10
R255	RESISTOR	10K ELR10
R256	RESISTOR	1K ELR10

PLL UNIT

REF. NO.	DESCRIPTION	TYPE (PART NO.)	
R257	RESISTOR	10K	ELR10
R258	RESISTOR	120K	R10
R259	RESISTOR	2.2K	ELR10
R260	RESISTOR	68K	ELR10
R261	RESISTOR	6.8K	ELR10
R262	RESISTOR	10K	ELR10
R263	RESISTOR	10K	ELR10
R264	THERMISTOR	33D28	
R265	THERMISTOR	33D28	
R266	RESISTOR	15K	ELR10
R267	RESISTOR	15K	ELR10
R268	RESISTOR	560K	ELR10
R269	RESISTOR	22K	ELR10
R270	RESISTOR	220K	ELR10
R271	RESISTOR	82K	ELR10
R272	TRIMMER	RHM0AJ406A	22K
R273	RESISTOR	2.2K	ELR10
R274	RESISTOR	22K	ELR10
R275	TRIMMER	RHM0AJ305A	2.2K
R276	RESISTOR	8.2K	ELR10
R277	RESISTOR	47K	ELR10
R278	RESISTOR	1M	ELR10
R279	RESISTOR	27	ELR10
R280	RESISTOR	5.6K	ELR10
R281	RESISTOR	47K	ELR10
R282	RESISTOR	47K	ELR10
R283	RESISTOR	10K	ELR10
R284	RESISTOR	82K	ELR10
R285	RESISTOR	220K	ELR10
R286	RESISTOR	100	ELR10
R287	RESISTOR	6.8K	ELR10
R288	RESISTOR	6.8K	ELR10
R289	RESISTOR	8.2K	ELR10
R290	RESISTOR	4.7K	ELR10
R291	RESISTOR	5.6K	ELR10
R292	RESISTOR	470	ELR10
R293	RESISTOR	100	ELR10
C201	CERAMIC	0.001	50V
C202	CERAMIC	3P	50V
C203	CERAMIC	0.001	50V
C204	CERAMIC	0.001	50V
C205	CERAMIC	0.5P	50V (#01, #03)
	CERAMIC	1P	50V (#02)
C206	CERAMIC	0.001	50V
C207	CERAMIC	0.001	50V
C208	CERAMIC	0.001	50V
C209	CERAMIC	2P	50V
C210	CERAMIC	0.5P	50V (#01, #03)
	CERAMIC	1P	50V (#02)
C211	CERAMIC	0.001	50V
C212	CERAMIC	2P	50V
C213	CERAMIC	0.5P	50V (#01, #03)
	CERAMIC	1P	50V (#02)
C214	CERAMIC	0.001	50V
C215	CERAMIC	6P	50V
C216	CERAMIC	1P	50V
C217	CERAMIC	22P	50V
C218	CERAMIC	0.001	50V
C219	CERAMIC	0.001	50V
C220	CERAMIC	47P	50V
C221	CERAMIC	5P	50V (#01, #02)
	CERAMIC	15P	50V (#03)
C222	CERAMIC	47P	50V

PLL UNIT

REF. NO.	DESCRIPTION	TYPE (PART NO.)	
C223	CERAMIC	4P	50V
C224	BARRIER LAY	0.0047	25V
C225	CERAMIC	0.001	50V
C226	ELECTROLYTIC	1	50V RC2
C227	BARRIER LAY	0.0047	25V
C228	ELECTROLYTIC	10	16V RC2
C229	CERAMIC	0.001	50V
C231	ELECTROLYTIC	47	6.3V RC2
C232	CERAMIC	10P	50V
C233	CERAMIC	470P	50V
C234	CERAMIC	0.001	50V
C235	ELECTROLYTIC	10	16V RC3
C236	CERAMIC	5P	50V
C237	CERAMIC	0.001	50V
C238	CERAMIC	0.001	50V
C239	CERAMIC	1P	50V
C240	CERAMIC	0.001	50V
C241	CERAMIC	0.001	50V
C242	CERAMIC	0.001	50V
C243	CERAMIC	470P	50V
C244	CERAMIC	10P	50V
C245	CERAMIC	22P	50V
C247	CERAMIC	4P	50V
C248	CERAMIC	0.001	50V
C249	CERAMIC	10P	50V
C251	CERAMIC	4P	50V
C252	CERAMIC	RPE121C104M50	0.1
C253	CERAMIC	0.001	50V
C254	CERAMIC	10P	50V
C255	CERAMIC	0.001	50V
C256	BARRIER LAY	0.75	50V
C257	CERAMIC	2P	50V
C258	CERAMIC	10P	50V
C259	CERAMIC	10P	50V
C260	CERAMIC	2P	50V
C261	BARRIER LAY	0.75	50V
C262	CERAMIC	470P	50V
C263	CERAMIC	0.001	50V
C264	CERAMIC	15P	50V
C265	CERAMIC	15P	50V
C266	CERAMIC	15P	50V
C267	CERAMIC	2P	50V
C268	CERAMIC	27P	50V
C269	CERAMIC	8P	50V
C270	CERAMIC	12P	50V
C271	CERAMIC	120P	50V
C272	CERAMIC	470P	50V
C273	CERAMIC	0.001	50V
C274	CERAMIC	100P	50V
C275	ELECTROLYTIC	0.1	50V RC2
C276	TANTALUM	DN1V0R1M	
C277	ELECTROLYTIC	10	35V RC2
C278	TANTALUM	DN1V	2R2M
C279	ELECTROLYTIC	47	6.3V RC2
C280	ELECTROLYTIC	47	6.3V RC2
C281	CERAMIC	0.001	50V
C282	CERAMIC	0.001	50V
C283	BARRIER LAY	0.01	25V
C284	CERAMIC	100P	50V
C285	CERAMIC	0.001	50V
C286	CERAMIC	220P	50V
C287	CERAMIC	33P	50V CH
C288	TRIMMER	ECRGA020E30	20P
C289	CERAMIC	4P	50V CH

PLL UNIT

REF. NO.	DESCRIPTION	TYPE (PART NO.)	
C290	CERAMIC	0.001	50V
C291	TANTALUM	DN1C	4R7M
C292	CERAMIC	0.001	50V
C293	CERAMIC	0.001	50V
C294	TANTALUM	DN1C	4R7M
C295	CERAMIC	0.001	50V
C296	ELECTROLYTIC	10	16V RC2
C298	CERAMIC	470P	50V
C300	CERAMIC	470P	50V
C301	CERAMIC	0.001	50V
C302	CERAMIC	0.001	50V
C303	ELECTROLYTIC	2.2	50V RC2
C304	BARRIER LAY	150P	50V
C305	CERAMIC	0.5P	50V
C306	CERAMIC	0.001	50V
C307	CERAMIC	0.001	50V
C308	ELECTROLYTIC	10	35V RC2
C309	ELECTROLYTIC	47	6.3V RC2
C310	CERAMIC	0.001	50V
C311	CERAMIC	0.001	50V
C312	CERAMIC	5P	50V
C313	CERAMIC	0.001	50V
C314	CERAMIC	0.001	50V
C315	CERAMIC	0.001	50V
C316	CERAMIC	RPE121C104M50	0.1
C317	CERAMIC	0.001	50V
C318	CERAMIC	470P	50V

J201	CONNECTOR	HSJ-0836-01-010
J202	CONNECTOR	TNC102-N1-W1-L1
J203	CONNECTOR	HSJ-1102-01-040
J204	CONNECTOR	HEC-0747-01-010
J205	CONNECTOR	171255-1
J206	CONNECTOR	171255-1

EP201	P.C.B.	B-1146B
EP207	FILTER SEAT	41590
EP212	ALUMINIUM SEAT	42356
EP213	SHIELDING PLATE	41911
EP214	F.P.C.	B-1050
EP215	F.P.C.	B-1044
EP217	GROUND SPRING	41595

W205	JUMPER	JPW-02A
------	--------	---------

DISPLAY UNIT

REF. NO.	DESCRIPTION	TYPE (PART NO.)
IC601	IC	μPD7225G
IC602	IC	LR40872
IC603	IC	μPD4066BG
D601	DIODE	1SS190
D602	DIODE	1SS190
D603	DIODE	1SS190
D604	DIODE	1SS190
D605	DIODE	1SS190
D606	DIODE	1SS190
X601	CERALOCK	CSAC3.58MG

DISPLAY UNIT

REF. NO.	DESCRIPTION	TYPE (PART NO.)	
R604	CHIP	180K	MCR10
R605	CHIP	15K	MCR10
R606	CHIP	15K	MCR10
R607	CHIP	22K	MCR10
R608	CHIP	47K	MCR10
C601	MONOLITHIC	0.001	GRM40
C602	MONOLITHIC	30P	GRM40
C603	MONOLITHIC	30P	GRM40
C604	MONOLITHIC	0.001	GRM40
C605	MONOLITHIC	0.001	GRM40
C606	MONOLITHIC	0.001	GRM40
C607	CERAMIC	470P	50V
C608	MONOLITHIC	0.001	GRM40
C609	MONOLITHIC	0.001	GRM40
C610	MONOLITHIC	0.001	GRM40
C611	MONOLITHIC	47P	GRM40
C612	MONOLITHIC	0.001	GRM40
C613	MONOLITHIC	47P	GRM40
C614	MONOLITHIC	47P	GRM40
C615	MONOLITHIC	470P	GRM40

DS601	LAMP	BQ031-22403A
DS602	LCD	LP217A-E

EP603	P.C.B.	B-1049C
EP604	F.P.C.	B-1046A

LOGIC UNIT

REF. NO.	DESCRIPTION	TYPE (PART NO.)
IC701	IC	μPD446C
IC702	IC	μPD4066BG
IC703	IC	μPD78C06A
IC704	IC	μPD4069UBG
IC705	IC	μPD4066BG
IC706	IC	MN6520
Q701	TRANSISTOR	2SC2712 Y
Q702	TRANSISTOR	2SC2712 Y
Q703	TRANSISTOR	2SA1162 Y
Q704	TRANSISTOR	2SA1162 Y

D703	DIODE	1SS181
D704	DIODE	1SS181
D706	ZENER	RD5.1M B2
D707	DIODE	1SS184
D708	DIODE	1SS181
D709	DIODE	1S953

X701	CRYSTAL	RF-4A3FACNHD
------	---------	--------------

R701	CHIP	47K	MCR10
R702	CHIP	47K	MCR10
R703	CHIP	47K	MCR10
R704	CHIP	47K	MCR10
R705	CHIP	47K	MCR10
R706	CHIP	47K	MCR10
R707	CHIP	47K	MCR10
R708	CHIP	47K	MCR10
R709	CHIP	820K	MCR10
R711	CHIP	10K	MCR10

LOGIC UNIT

REF. NO.	DESCRIPTION	TYPE (PART NO.)	
R712	CHIP	10K	MCR10
R713	CHIP	10K	MCR10
R714	CHIP	15K	MCR10
R715	CHIP	10K	MCR10
R716	CHIP	4.7K	MCR10
R717	CHIP	470K	MCR10
R718	CHIP	6.8K	MCR10
R719	CHIP	820	MCR10
R720	CHIP	47K	MCR10
R721	CHIP	68K	MCR10
R722	CHIP	15K	MCR10
R724	CHIP	1M	MCR10
R726	CHIP	100K	MCR10
R727	CHIP	1M	MCR10
R728	CHIP	220K	MCR10
R729	CHIP	470K	MCR10
R730	CHIP	47K	MCR10
R731	CHIP	1K	MCR10
R732	CHIP	47K	MCR10
R733	RESISTOR	0	MCR10
C701	MONOLITHIC	0.1	GRM40 F

LOGIC UNIT

REF. NO.	DESCRIPTION	TYPE (PART NO.)	
C702	MONOLITHIC	5P	GRM40
C703	MONOLITHIC	18P	GRM40
C705	ELECTROLYTIC	22	6.3V RC3
C706	MONOLITHIC	0.1	GRM40 F
C707	ELECTROLYTIC	1	50V RC3
C708	MONOLITHIC	0.01	GRM40 F
C709	ELECTROLYTIC	22	16V RC3
C711	ELECTROLYTIC	0.1	50V RC3
C712	MONOLITHIC	0.1	GRM40 F
C713	MONOLITHIC	0.01	GRM40 F
C714	MONOLITHIC	0.01	GRM40 F
C716	MONOLITHIC	47P	GRM40
C717	MONOLITHIC	0.01	GRM40 F
C718	MONOLITHIC	0.001	GRM40
C719	MONOLITHIC	0.01	GRM40 F
C720	MONOLITHIC	0.1	GRM40 F
C722	TANTALUM	3.3	16V
EP702	P.C.B.	B-1048D	
EP703	SHIELDING PLATE(C)	40639	

SECTION 11 IC SPECIFICATIONS

μPD78C06A (MPU)

MAXIMUM RATINGS (Ta = 25°C)

DESCRIPTION	SYMBOL	RATINGS	UNIT
Supply Voltage	V _{CC}	-0.3~7.0	V
Input And Output Voltage	V _I	-0.3~V _{CC} +0.3	V
Output Current (High level)	I _{OH}	-5	mA
Output Current (Low level)	I _{OL}	43.5	mA
Operating Temperature	T _{OPR}	-40~85	°C
Storage Temperature	T _{STG}	-65~150	°C

PIN CONNECTION

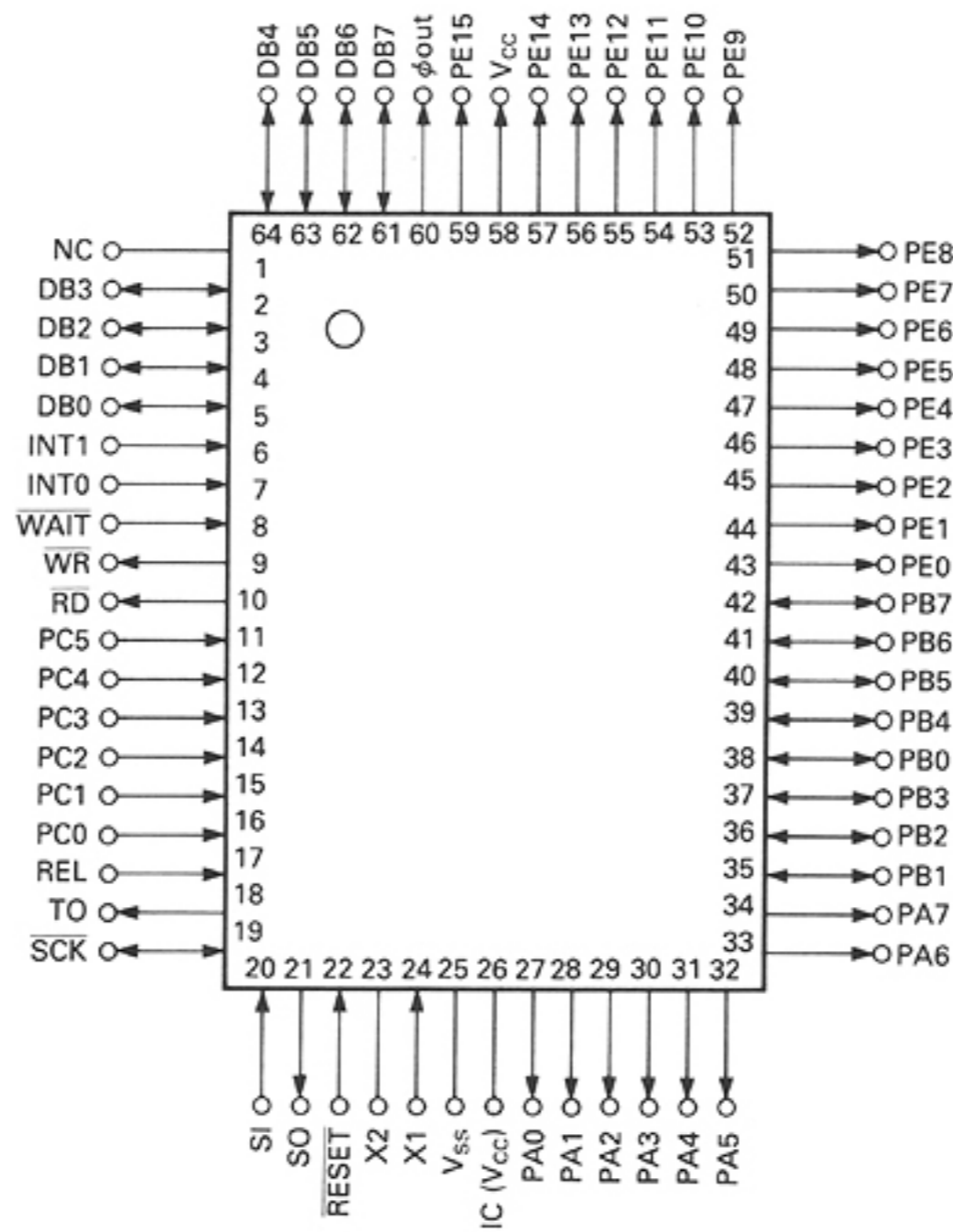

μPD446 (16384 BIT STATIC CMOS RAM)

MAXIMUM RATINGS (Ta = 25°C)

DESCRIPTION	SYMBOL	RATINGS	UNIT
Supply Voltage	V _{CC}	7.0	V
Input And Output Voltage	V _I	-0.3~V _{CC} +0.3	V
Operating Temperature	T _{OPR}	-40~85	°C
Storage Temperature	T _{STG}	-55~125	°C

PIN CONNECTION

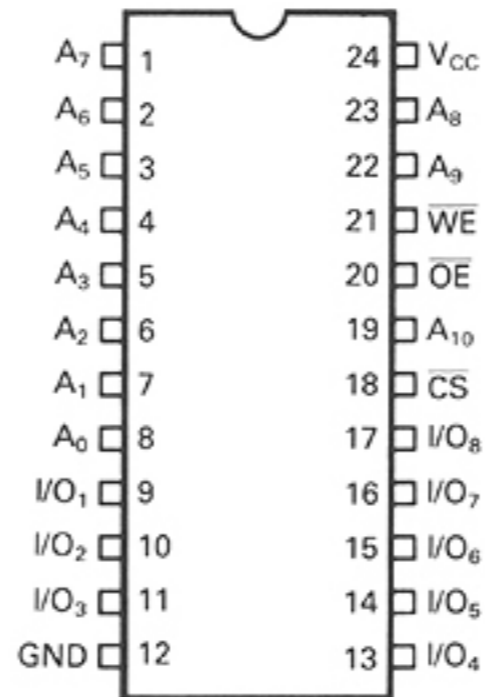

BLOCK DIAGRAM

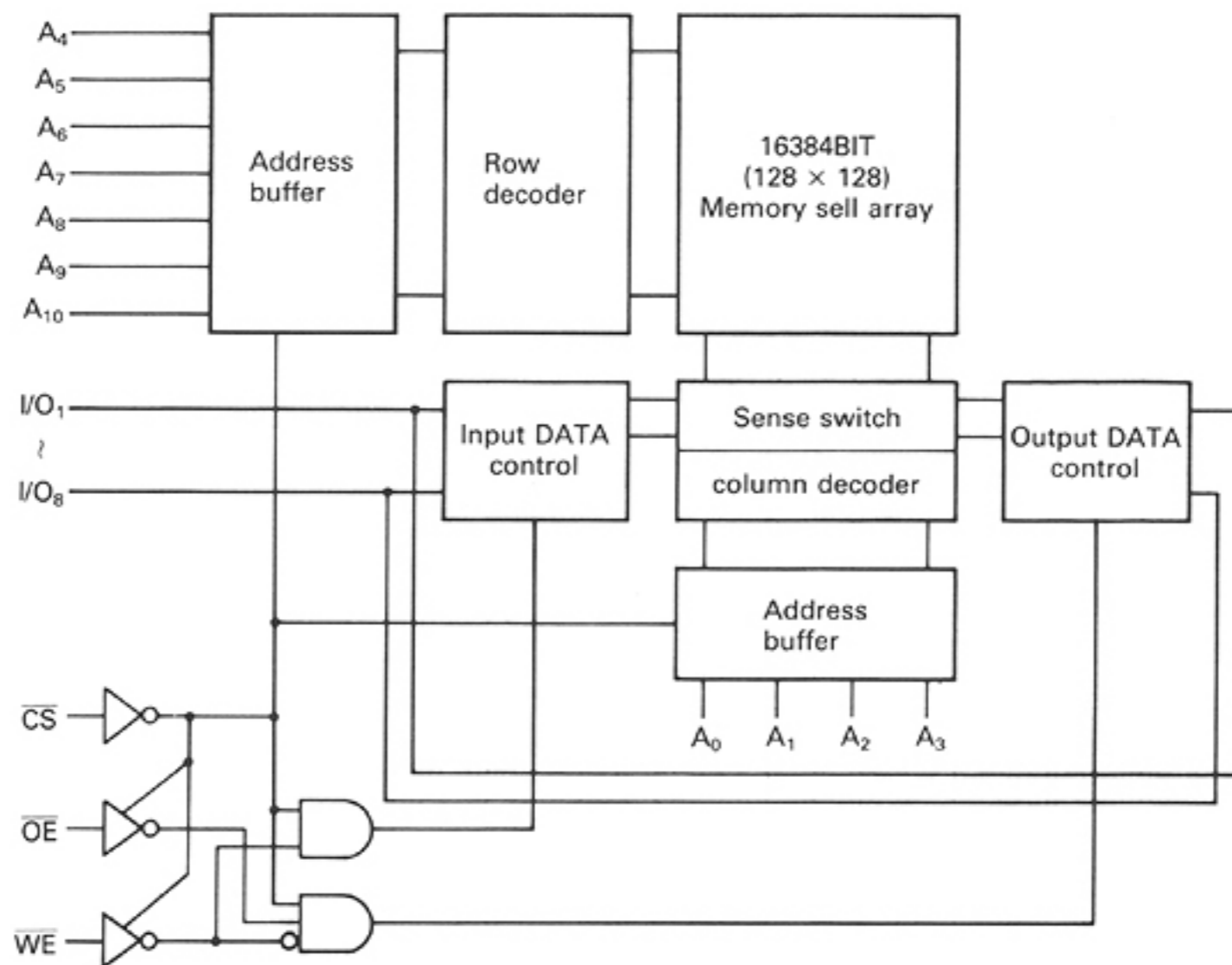

μPD2834C (PLL FREQUENCY SYNTHESIZER)

MAXIMUM RATINGS (Ta = 25°C)

DESCRIPTION	SYMBOL	RATINGS	UNIT	REMARKS
Supply Voltage	V _{DD}	-0.3~+7.0	V	
Input Voltage	V _{IN}	-0.5~+V _{DD} +0.5	V	
Output Voltage	V _{OUT}	-0.5~+V _{DD} +0.5	V	
Output Voltage	V _{OUT}	-0.5~+V _{DD} +3.0	V	EOU pins only
Operating Temperature	T _{OPR}	-40~+85	°C	
Storage Temperature	T _{STR}	-65~+150	°C	

PIN CONNECTION

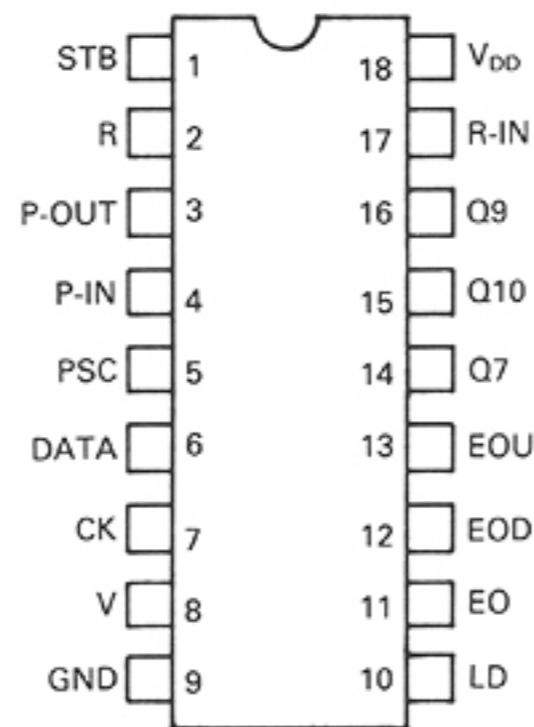

BLOCK DIAGRAM

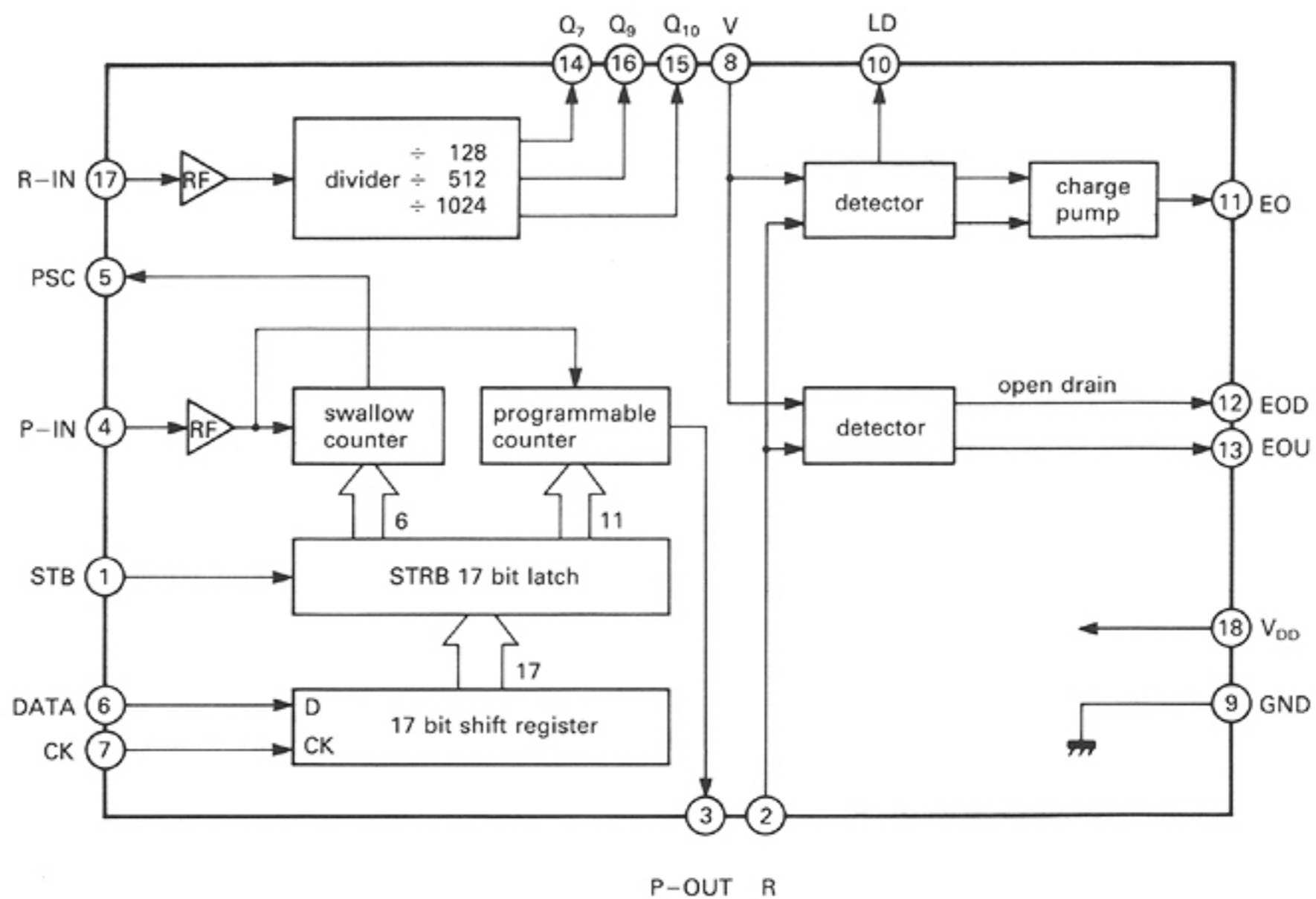

MB504 (HIGH SPEED PRESCALER)

MAXIMUM RATINGS (ta = 25°C)

DESCRIPTION	SYMBOL	RATINGS	UNIT
Supply Voltage	V _{CC}	4.5~5.5	V
Input Voltage	V _{IN}	0.15~2.0	V _{P-P}
Output Current	I _O	1.2	mA
Operating Temperature	T _{OPR}	-40~85	°C

PIN CONNECTION

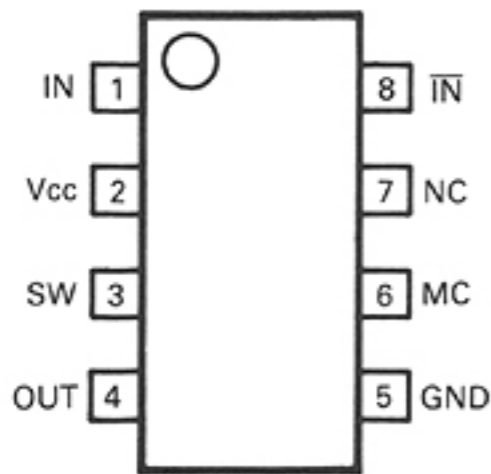

DIVIDE RATIO

SW	MC	Divide Ratio
H	H	1/32
H	L	1/33
L	H	1/64
L	L	1/65

BLOCK DIAGRAM

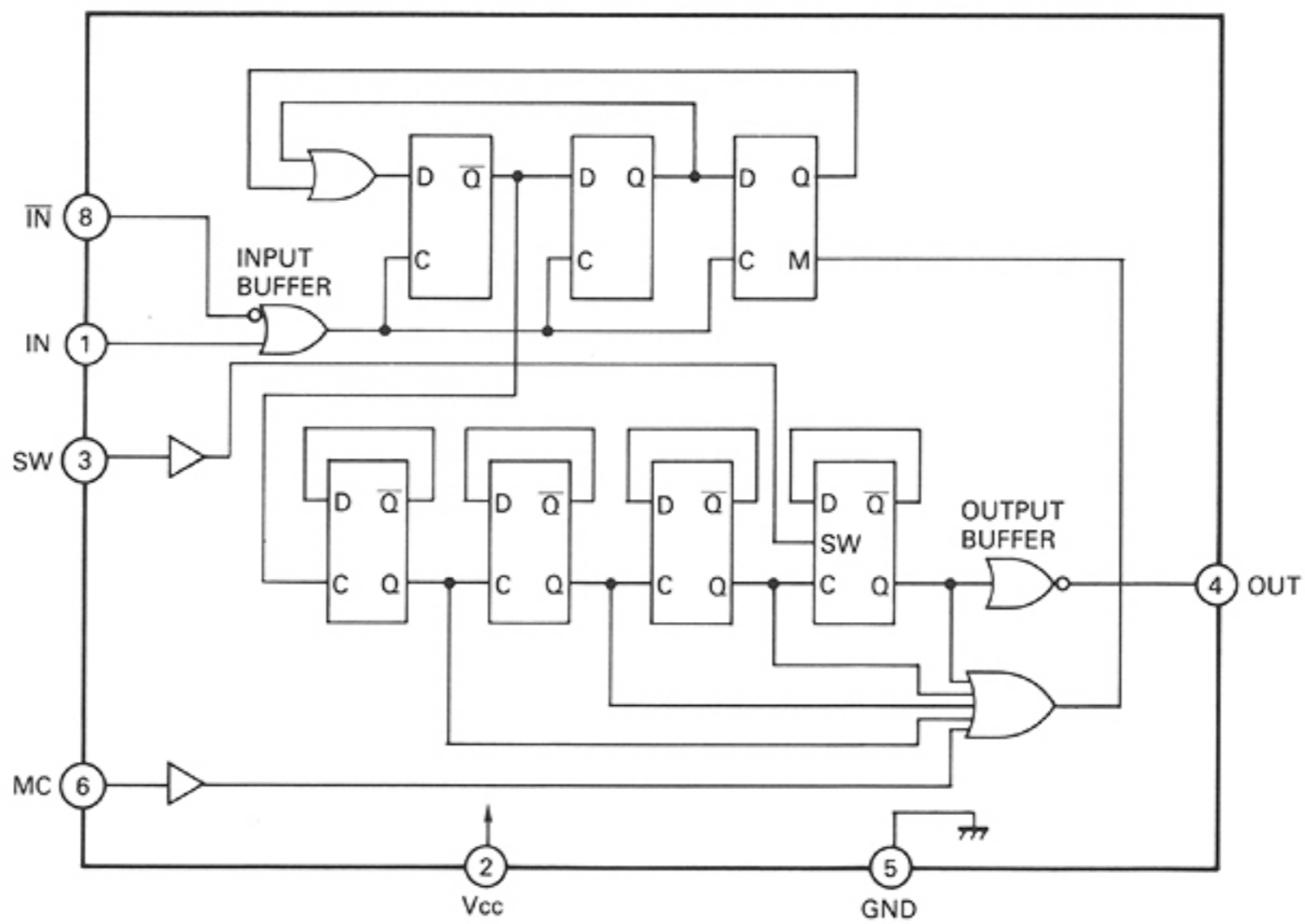

MC3357 (LOW POWER FM IF)

MAXIMUM RATINGS

DESCRIPTION	SYMBOL	RATINGS	UNIT
Power Supply Voltage	V _{cc} (max)	12	V
Operating Supply Voltage	V _{cc}	4 or 8	V
Detector Input Voltage	—	1.0	V _{p-p}
Input Voltage (V _{cc} ≥ 6.0 Volts)	V ₁₆	1.0	V _{RMS}
Mute Function	V ₁₄	-0.5 ~ 5.0	V _{pk}
Junction Temperature	T _J	150	°C
Operating Temperature	T _{OPR}	-30 ~ 70	°C
Storage Temperature	T _{STG}	-65 ~ 150	°C

PIN CONNECTION

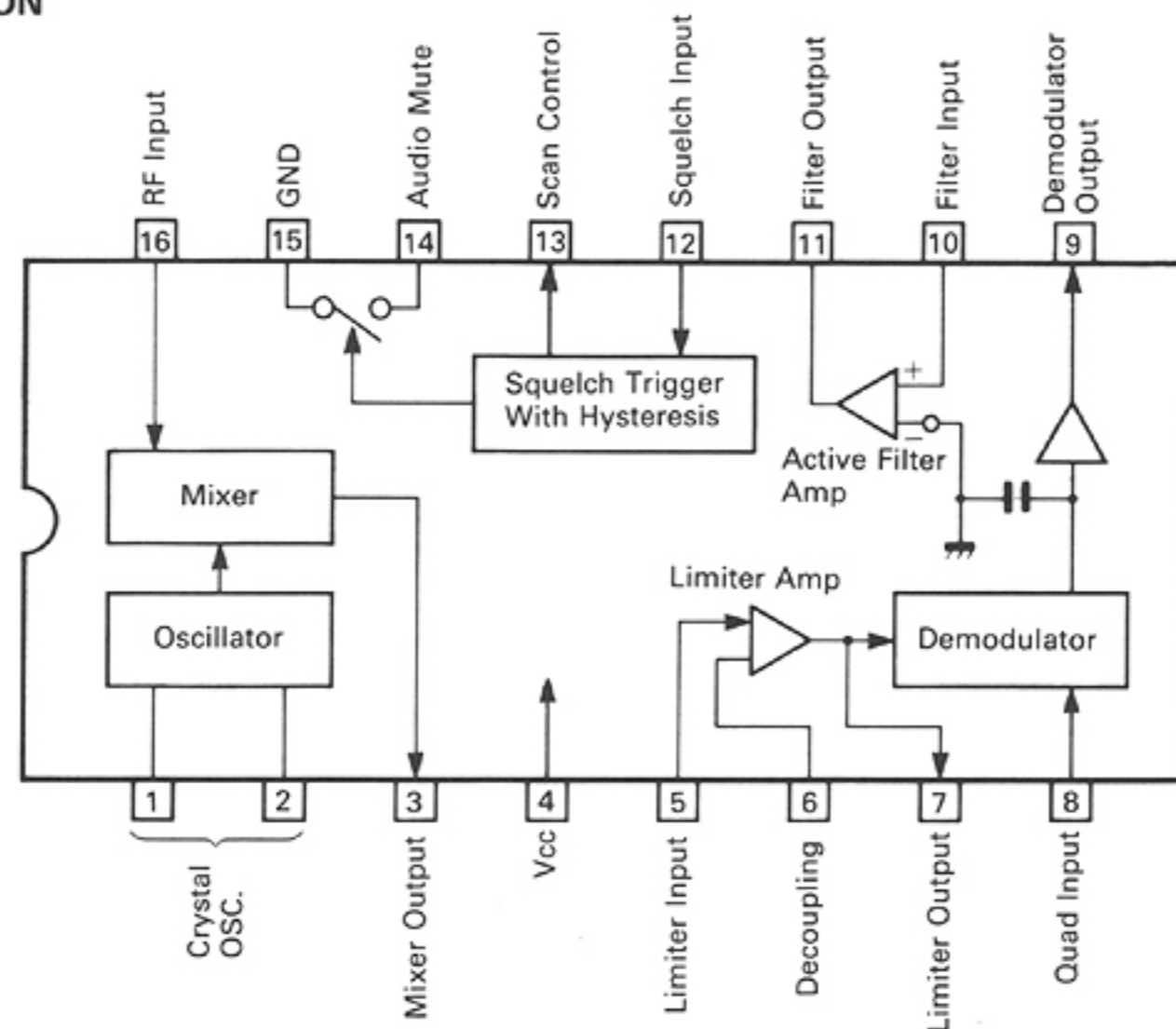

LM386N-3 (LOW VOLTAGE AUDIO POWER AMPLIFIER)

MAXIMUM RATINGS (T_a = 25°C)

DESCRIPTION	SYMBOL	RATINGS	UNIT
Supply Voltage	V _{cc}	15	V
Package Dissipation	P _D	600	mW
Drive Input Voltage	DV _{IN}	+0.4	V
Operating Temperature	T _{OPR}	0 ~ 70	°C
Storage Temperature	T _{STG}	-65 ~ 150	°C

PIN CONNECTION

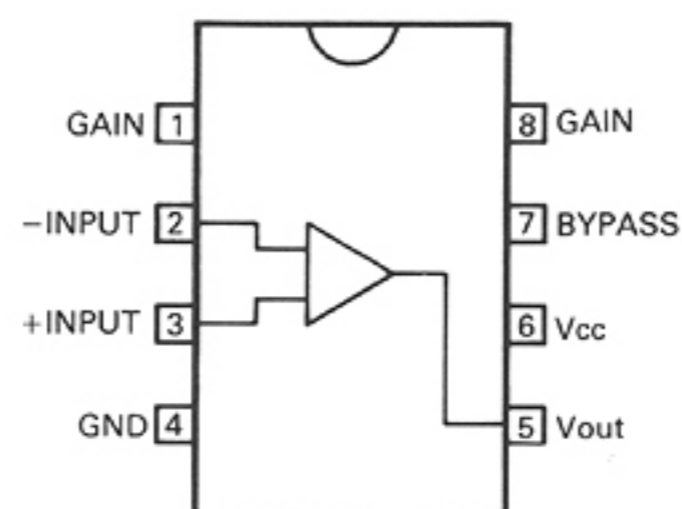

SC-1046, SC-1050 (VHF POWER AMPLIFIER)

MAXIMUM RATINGS

DESCRIPTION	SYMBOL	RATINGS	UNIT
Supply Voltage	V_{CC}	16	V
Bias Voltage	V_{BB}	6	V
Input Power	P_i	40	mW
Operating Temperature	T_{OPR}	-30~100	°C
Storage Temperature	T_{STG}	-40~110	°C

PIN CONNECTION

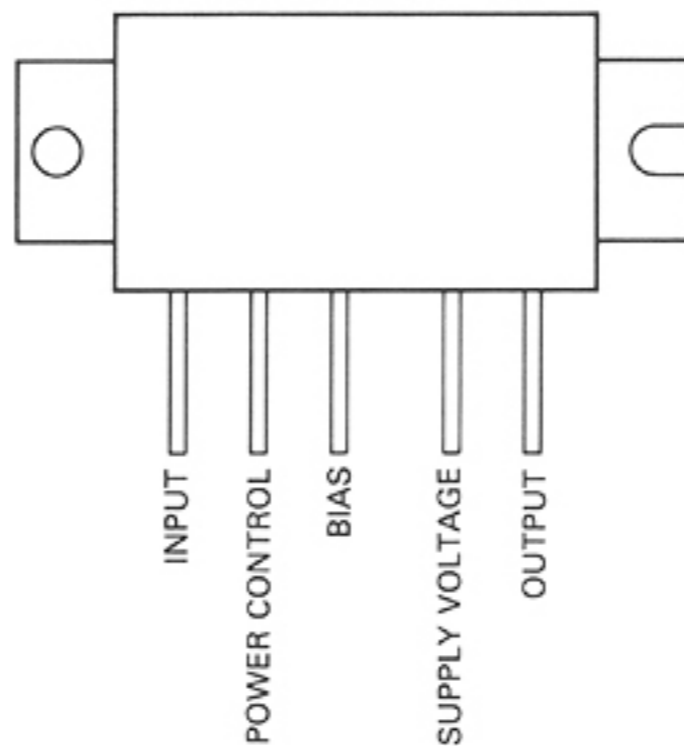

μ PC358C (DUAL DRIVER)

MAXIMUM RATINGS ($T_a = 25^\circ\text{C}$)

DESCRIPTION	SYMBOL	RATINGS	UNIT
Supply Voltage	V_{CC}	32	V
Drive Input Voltage	DV_{IN}	32	V
Input Voltage	V_{IN}	-0.3~32	V
Permissible Dissipation	P_D	350	mW
Operating Temperature	T_{OPR}	0~70	°C
Storage Temperature	T_{STG}	-55~125	°C

PIN CONNECTION

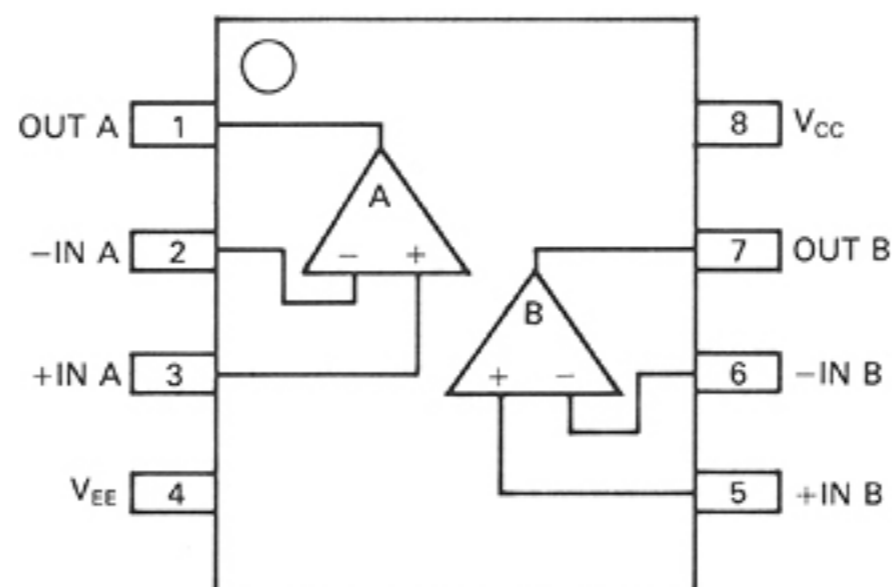

μPD4066BG (QUAD BILATERAL SWITCH)

MAXIMUM RATINGS (Ta = 25°C)

DESCRIPTION	SYMBOL	RATINGS	UNIT
Supply Voltage	V _{DD}	-0.5~20	V
Input Voltage	V _{IN}	-0.5~V _{DD} +0.5	V
Input Current	I _{IN}	10	mA
Permissible Dissipation	P _D	200	mW
Operating Temperature	T _{OPR}	-40~85	°C
Storage Temperature	T _{STG}	-65 ~ 125	°C

PIN CONNECTION

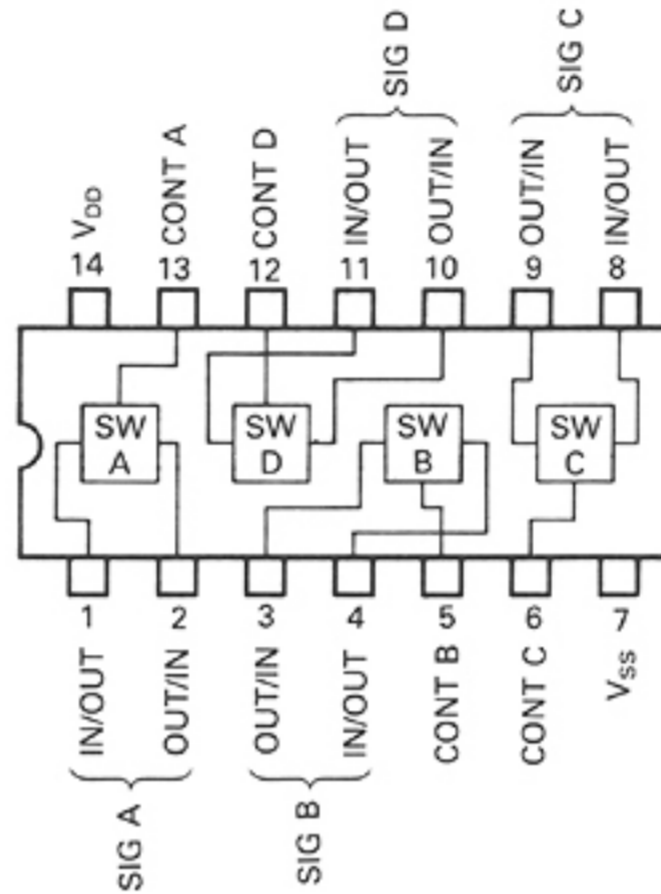

μPD4069UBG (HEX INVERTER)

MAXIMUM RATINGS

DESCRIPTION	SYMBOL	RATINGS	UNIT
Supply Voltage	V _{DD}	V _{SS} -0.5~V _{SS} +20	V
Input Voltage	V _{IN}	V _{SS} -0.5~V _{DD} +0.5	V
Output Voltage	V _{OUT}	V _{SS} -0.5~V _{DD} +0.5	V
Input Current	I _{IN}	±10	mA
Permissible Dissipation	P _D	300	mW
Storage Temperature	T _{STG}	-65~150	°C

PIN CONNECTION

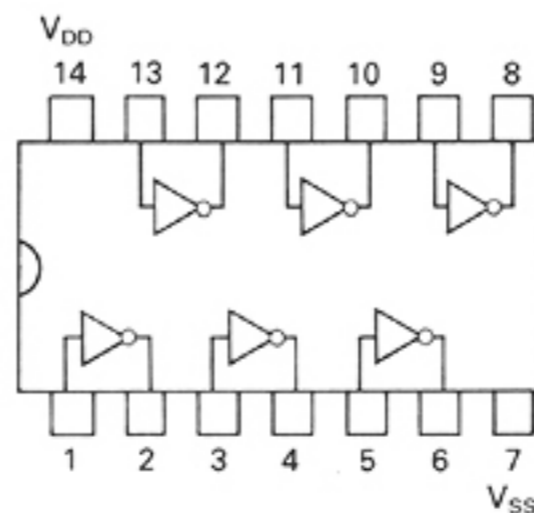

μPD 7225G (PROGRAMMABLE LCD DRIVER)

MAXIMUM RATINGS (Ta = 25°C)

DESCRIPTION	SYMBOL	RATINGS	UNIT
Supply Voltage	V _{DD}	-0.3~7.0	V
Input Voltage	V _{IN}	-0.3~V _{DD} +0.3	V
Output Voltage	V _{OUT}	-0.3~V _{DD} +0.3	V
Operating Temperature	T _{OPR}	-10~70	°C
Storage Temperature	T _{STG}	-65~150	°C

PIN CONNECTION

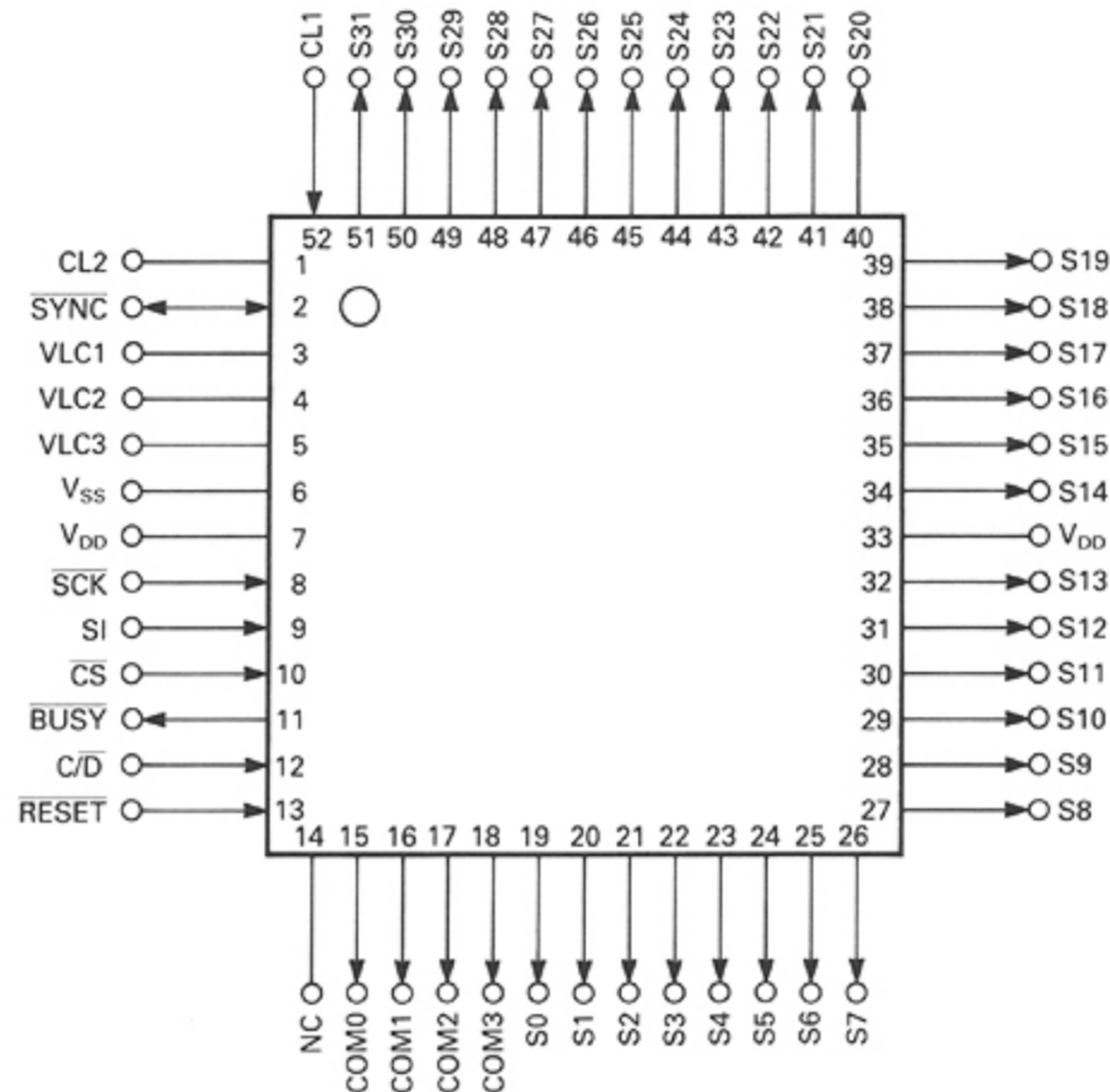

BLOCK DIAGRAM

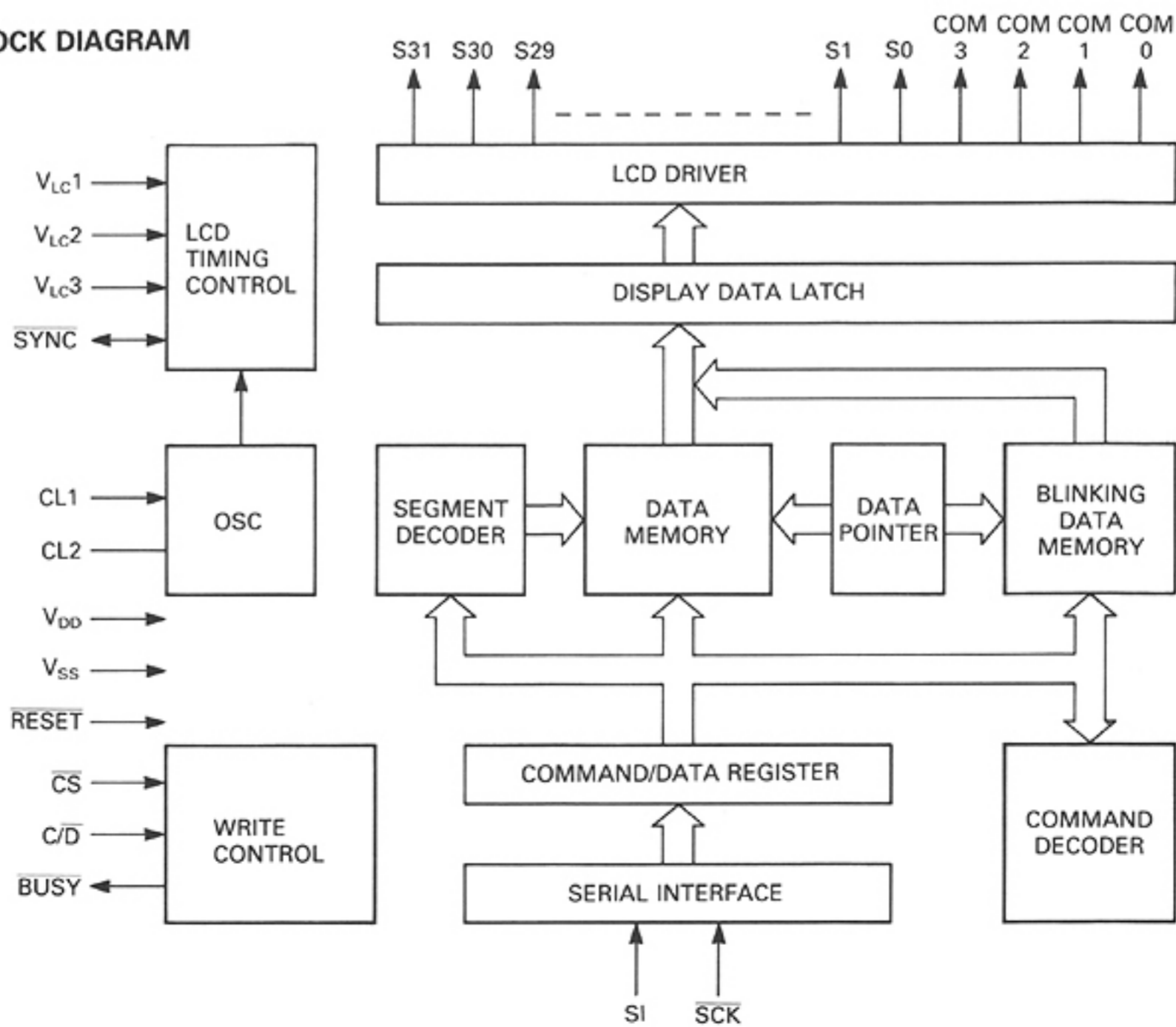

LR40872 (DUAL TONE MULTI FREQUENCY IC)

MAXIMUM RATINGS (Ta = 25°C)

DESCRIPTION	SYMBOL	RATINGS	UNIT
Supply Voltage	V _{CC}	10.5	V
Input Voltage	V _{IN}	-0.3~V _{CC} +0.3	V
Power Dissipation	P _D	500	mW
Operating Temperature	T _{OPR}	-30~60	°C
Storage Temperature	T _{STG}	-55 ~ 150	°C

PIN CONNECTION

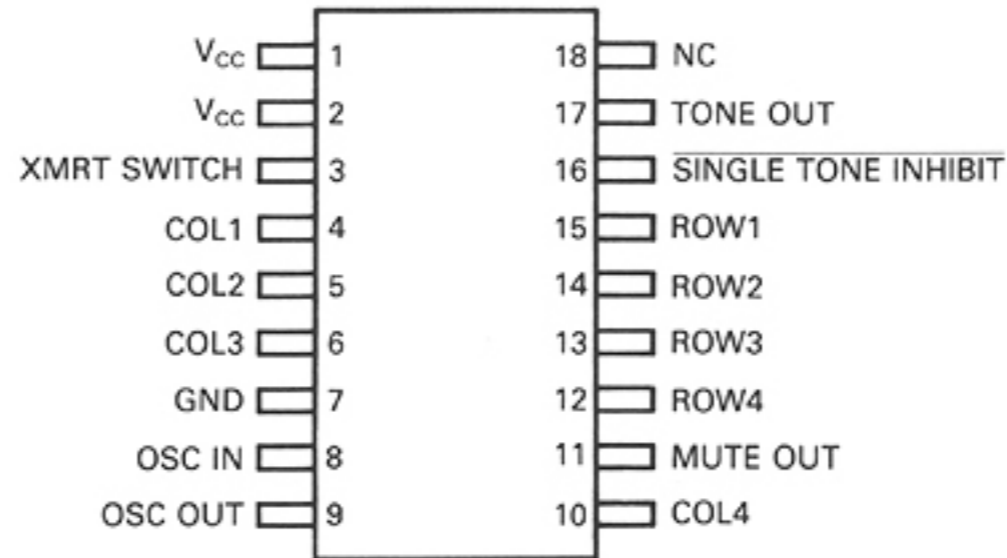

MN6520 (CTCSS ENCODER DECODER)

MAXIMUM RATINGS (Ta = 25°C)

DESCRIPTION	SYMBOL	RATINGS	UNIT
Supply Voltage	V _{DD}	-0.2~7.0	V
Input And Output Voltage	V _I	-0.2~V _{DD} +0.2	V
Power Dissipation	P _D	100	mW
Operating Temperature	T _{OPR}	-20~70	°C
Storage Temperature	T _{STG}	-55~100	°C

PIN CONNECTION

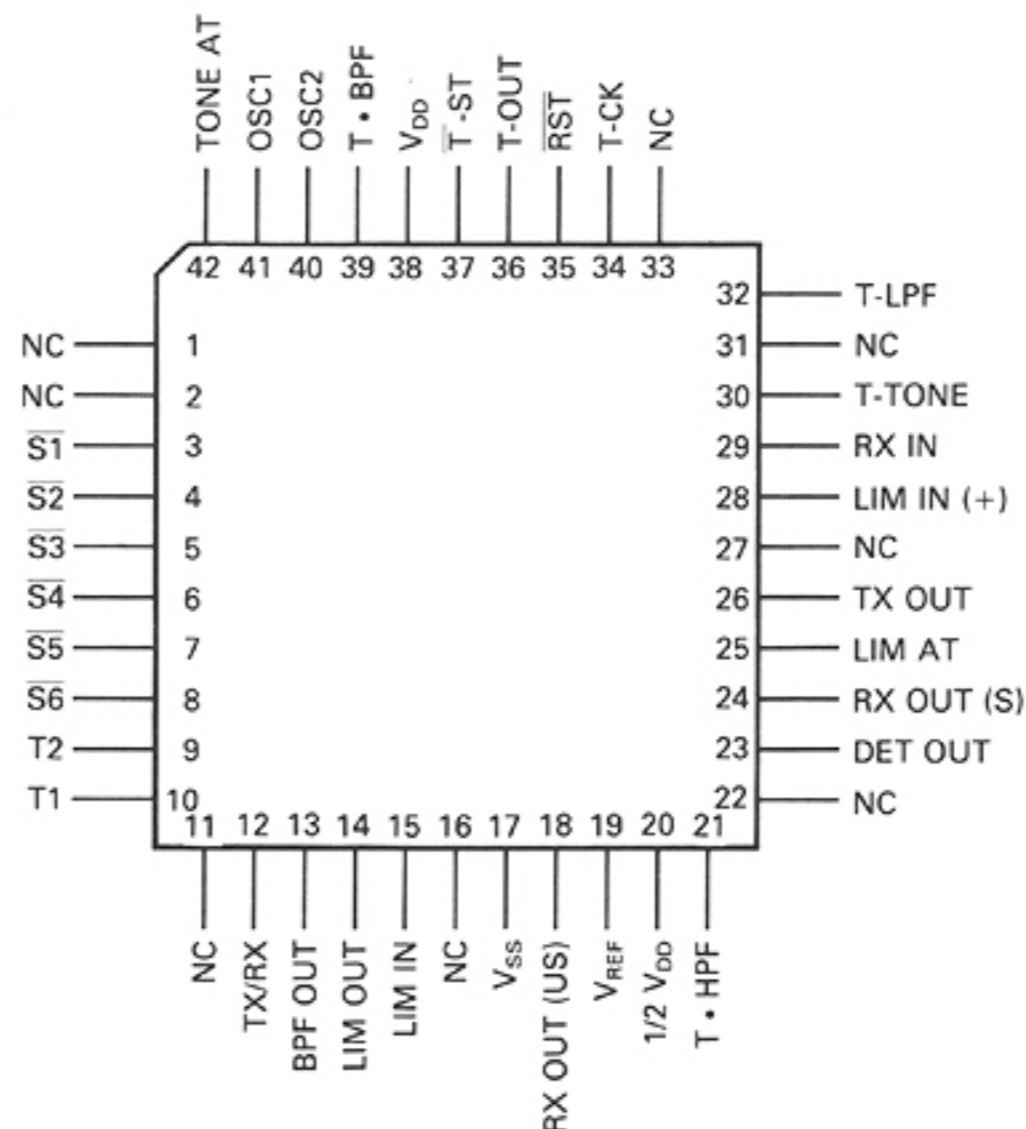

SECTION 12 BATTERY PACK SCHEMATIC DIAGRAMS

12-1 IC-CM7

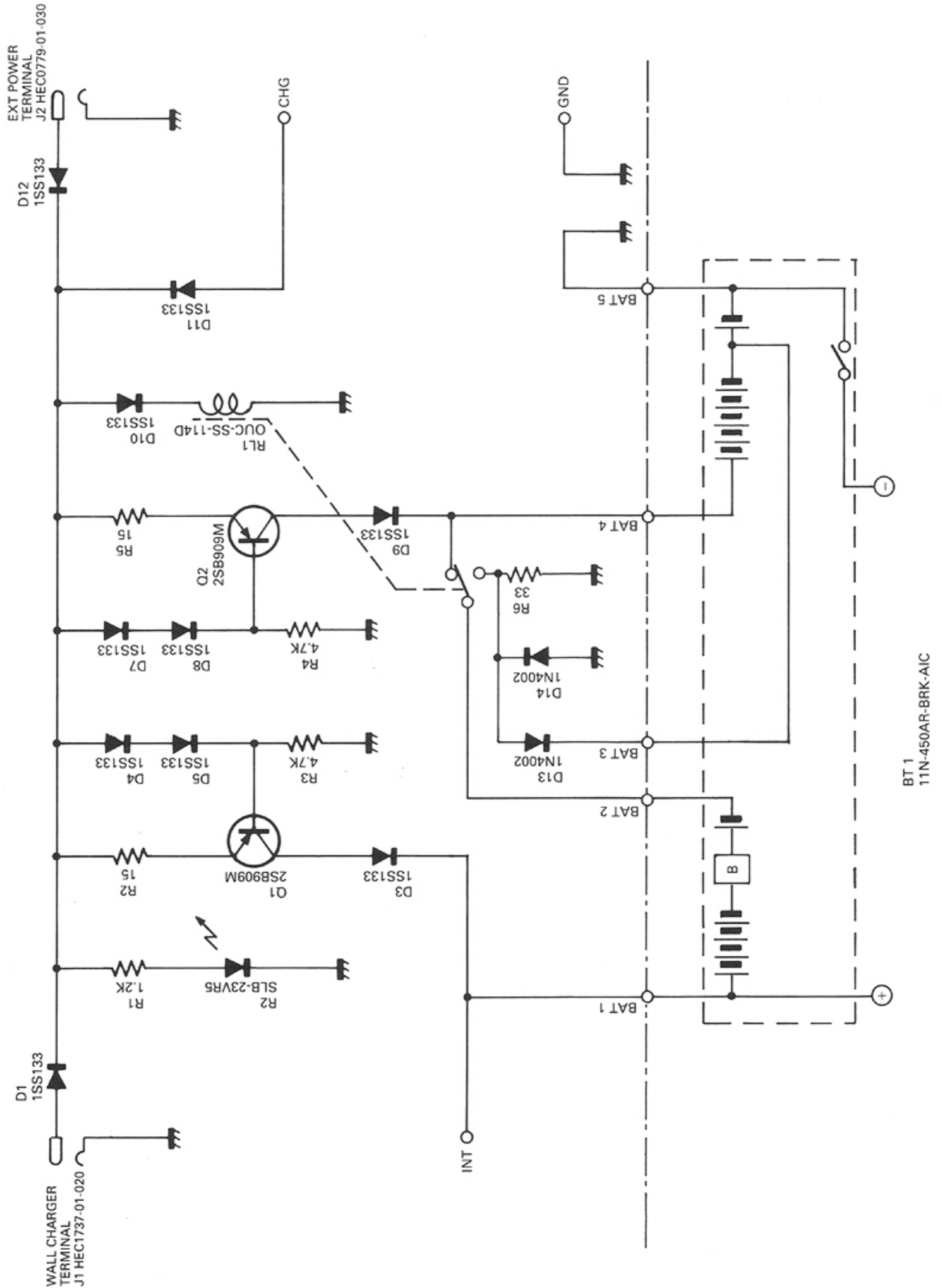

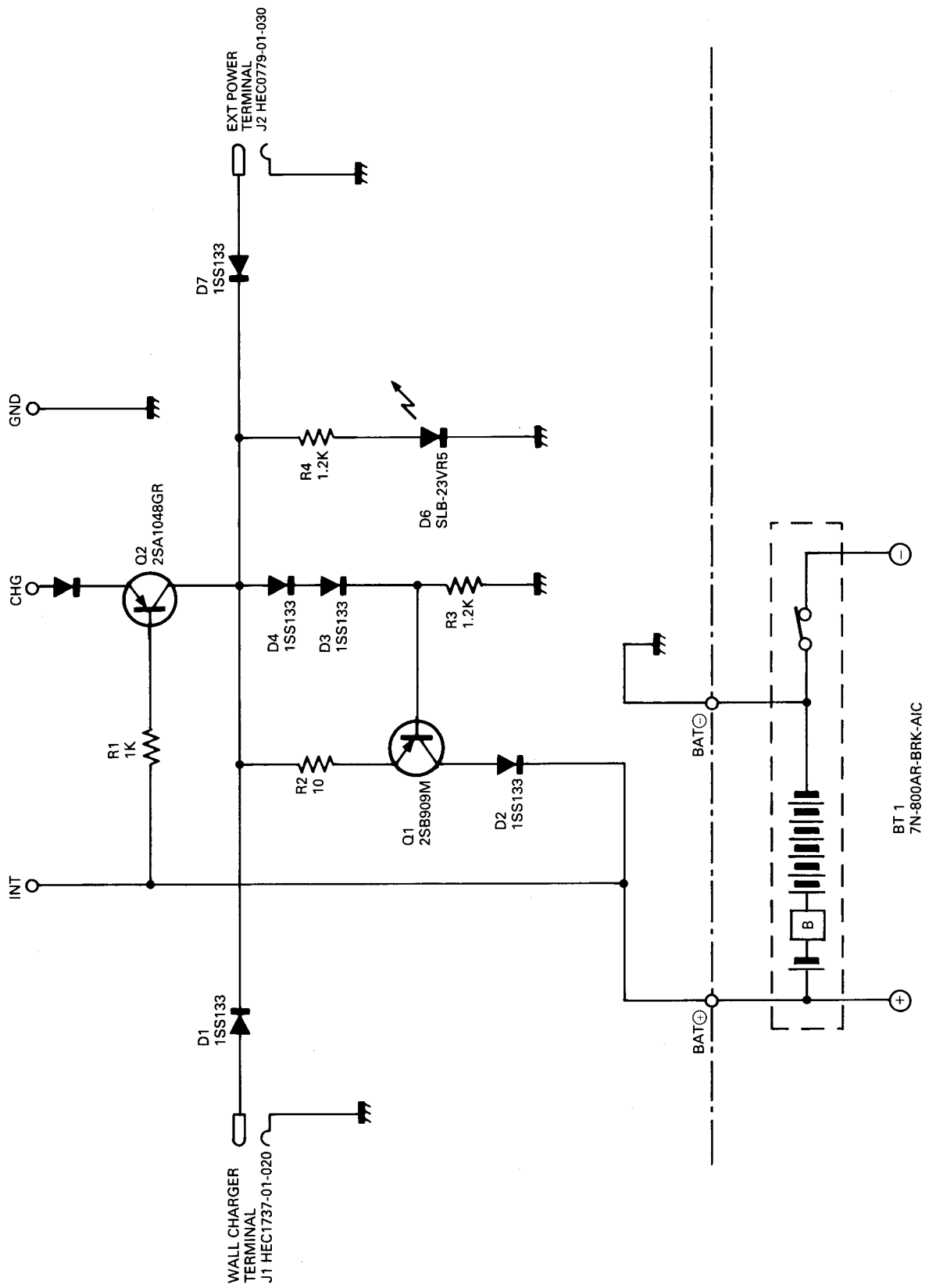

IC-H16

SCHEMATIC DIAGRAM

